

2.4 Assembly Drawing

2.4.1 Assembly Drawing

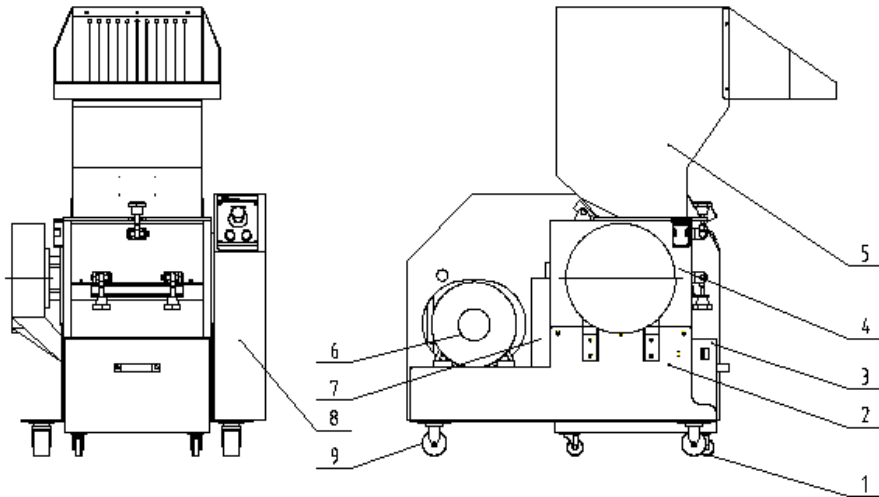

Note: Please refer to 2.3.2 material list about the parts code.

Picture 2-5: Assembly Drawing

2.4.2 Parts List

Table 2-1: Parts List

No.	Name	SG-2130EB		SG-2540EB	
		Part No.	Qua.	Part No.	Qua.
1	Fixed castor 3"	YW03000300500	2	YW03000300500	2
2	Rack assembly	BK54231000020	1	BK54254000020	1
3	Collection box assembly	-	1	-	1
4	Cutting chamber assembly	BH85231000050	1	BH85254000050	1
5	Feed box assembly	-	1	-	1
6	Main drive	-	1	-	1
7	Seal plate	-	1	-	1
8	Shield assembly	-	1	-	1
9	Castor 3" with brake	YW03000300900	2	YW03000300900	2
No.	Name	SG-2950EB		SG-3260EB	
		Part No.	Qua.	Part No.	Qua.
1	Fixed castor 3"	YW03000300500	2	YW03000300500	2
2	Rack assembly	BK54295000020	1	BK54326000020	1
3	Collection box assembly	-	1	-	1
4	Cutting chamber assembly	BH85295000050	1	BH85326000050	1
5	Feed box assembly	-	1	-	1

6	Main drive	-	1	-	1
7	Seal plate	-	1	-	1
8	Shield assembly	-	1	-	1
9	Castor 3" with brake	YW03000300900	2	YW03000300900	2
No.	Name	SG-4880EB		SG-60110EB	
		Part No.	Qua.	Part No.	Qua.
1	Fixed castor 3"	YW03000300200 (3")	4	YW03000400200 (4")	4
2	Rack assembly	BK54488000020	1	-	1
3	Collection box assembly	-	1	-	1
4	Cutting chamber assembly	BH85488000150	1	-	1
5	Feed box assembly	-	1	-	1
6	Main drive	-	1	-	1
7	Seal plate	-	1	-	1
8	Shield assembly	-	1	-	1
9	Castor 3" with brake	-	-	-	-

* means possible broken parts.

** means easy broken part. and spare backup is suggested.

Please confirm the version of manual before placing the purchase order to guarantee that the item number of the spare part is in accordance with the real object.

2.4.3 Main Drive

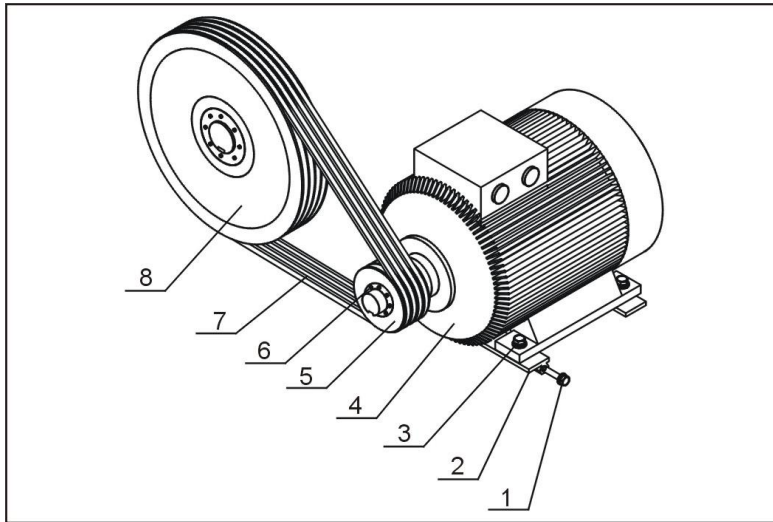

Note: The Arabic numerals of the parts refer to Parts List 2.3.4

Picture 2-6: Drawing of Main Drive

2.4.4 Parts List of Main Drive

Table 2-2: Parts List of Main Drive

No.	Name	SG-2130EB		SG-2540EB	
		Part No.	Qua.	Part No.	Qua.
1	Hexagon screw M10×80	YW60108000000	2	YW60108000000	2
2	Motor adjusting plate	BH10236100010	2	BH10236100010	2
3	Hexagon screw	YW60104000100	4	YW60104000100	4
4	Motor	YM10205500600	1	YM10207500600	1
5	Motor pulley	YW30118400000	1	YW30118400000	1
6	Pulley sleeve	YW30203800000	1	YW30203800000	1
7	Triangle belt	YR00155000000	4	YR00160000000	4
8	Big pulley with sleeve	YW30315400000	1	YW30315400000	1
No.	Name	SG-2950EB		SG-3260EB	
		Part No.	Qua.	Part No.	Qua.
1	Hexagon screw M10×80	YW60108000000	2	YW60108000000	2
2	Motor adjusting plate	BH10306500110	2	BH10306500110	2
3	Hexagon screw	YW60124500000	4	YW60124500000	4
4	Motor	YM10201100700	1	YM10201500600	1
5	Motor pulley	YW30118400000	1	YW30112400100	1
6	Pulley sleeve	YW30204200500	1	YW30204200500	1
7	Triangle belt	YR00167600000	4	YR00180000000	4
8	Big pulley with sleeve	YW30315400200	1	YW30335400000	1

No.	Name	SG-4880EB		SG-60110EB	
		Part No.	Qua.	Part No.	Qua.
1	Hexagon screw	Left: YW61168500000 (M16x85) Right: YW61165000000 (M16x50)	Each1	YW61168500000 (M16x85)	2
2	Motor adjusting plate	-	2	-	2
3	Hexagon screw	YW60126000100	4	YW60166000000	4
4	Motor	YM10180420700	1	YM10202000700	1
5	Motor pulley	YW30150500000	1	YW30160600000	1
6	Pulley sleeve	YW30254800000	1	YW30302000000	1
7	Triangle belt	YR00215000000	5	YR00280000100	6
8	Big pulley with sleeve	YW30400500000	1	YW30450600000	1

* means possible broken parts.

** means easy broken part. and spare backup is suggested.

Please confirm the version of manual before placing the purchase order to guarantee that the item number of the spare part is in accordance with the real object.

2.4.5 Cutting Chamber Assembly 1

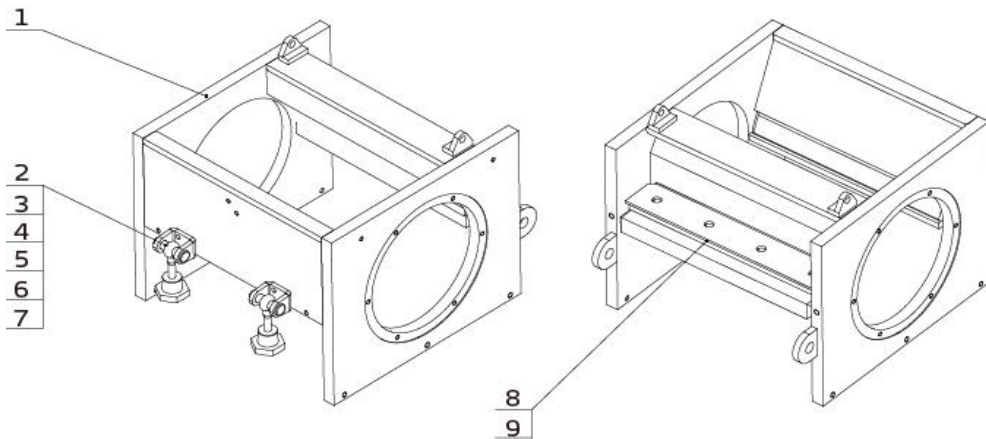

Note: The Arabic numerals of the parts refer to Parts List 2.3.6

Picture 2-7: Cutting Chamber Assembly 1

2.4.6 Parts List of Cutting Chamber Assembly 1

Table 2-3: Parts List of Cutting Chamber Assembly 1

No.	Name	SG-2130EB		SG-2540EB	
		Part No.	Qua.	Part No.	Qua.
1	Cutting Chamber	BH10213000010	1	BH10254000310	1
2	Hinge base	-	2	-	2
3	Shaft pin	YW09301400000	2	YW09301400000	2
4	A type of elastic ring for axes use 16	YW69001600000	2	YW69001600000	2
5	Star screw	YW09003010500	2	YW09003010500	2
6	Flat washer	YW66123200100	2	YW66123200100	2
7	Star nut (M12)	YW09001200500	2	YW09001200500	2
8	Pressing plate of rear fixed blade	BH10213000510	1	-	1
9	Fixed blade	YW41213000100	2	YW41254000100	2
No.	Name	SG-2950EB		SG-3260EB	
		Part No.	Qua.	Part No.	Qua.
1	Cutting Chamber	BH10295000010	1	BH10326000810	1
2	Hinge base	-	2		3
3	Shaft pin	YW09301400000	2	YW09301400000	3
4	A type of elastic ring for axes use 16	YW69001600000	2	YW69001600000	3
5	Star screw	YW09003010500	2	YW09003010500	3
6	Flat washer	YW66123200100	2	YW66123200100	3
7	Star nut (M12)	YW09001200500	2	YW09001200500	3
8	Pressing plate of rear fixed blade	BH10295001510	1	-	1

9	Fixed blade	YW41295000100	2	YW41326000100	4
No.	Name	SG-4880EB		SG-60110EB	
		Part No.	Qua.	Part No.	Qua.
1	Cutting Chamber	BL54488000220	1	-	1
2	Hinge base	BL54300003920	7	-	8
3	Shaft pin	YW09301400000	7	-	8
4	A type of elastic ring for axes use 16	YW69001600000	7	YW69002100000	8
5	Star screw	YW09003010500	7	BH10501100540	8
6	Flat washer	YW66123200100	7	YW66164000000	8
7	Star nut (M12)	YW64012100000 (M12)	4	YW64001600000 (M16)	10
8	Pressing plate of rear fixed blade	-	-	-	-
9	Fixed blade	YW42488000300	4	YW41601100000	4

* means possible broken parts.

** means easy broken part. and spare backup is suggested.

Please confirm the version of manual before placing the purchase order to guarantee that the item number of the spare part is in accordance with the real object.

2.4.7 Cutting Chamber Assembly 2 (SG-2130EB~4880EB)

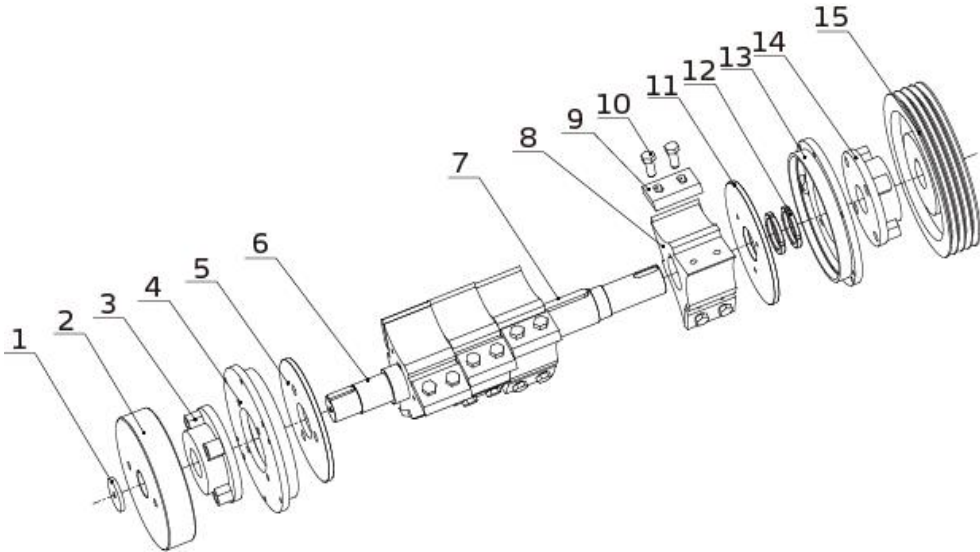

Note: The Arabic numerals of the parts refer to Parts List 2.3.8

Picture 2-8: Cutting Chamber Assembly 2

2.4.8 Parts List of Cutting Chamber Assembly 2 (SG-2130EB~4880EB)

Table 2-4: Parts List of Cutting Chamber Assembly 2

No.	Name	SG-2130EB		SG-2540EB	
		Part No.	Qua.	Part No.	Qua.
1	Pressing plate of fly wheel	-	1	-	1
2	Fly wheel	BH10254002110	1	BH10254002110	1
3	Left bearing	YW11021100000	1	YW11021100000	1
4	Left bearing base	BH10254002310	1	BH10254002310	1
5	Left material fender	BH10213000710	1	BH10254001310	1
6	Shaft	BH10213000610	1	BH10254001210	1
7	Flat key 18X11XL	BH10213001210	1	BH10254001910	1
8	Blade shaft	BH10213000810	3	BH1025400140	4
9	Rotating blade	YW41254000000	9	YW41254000000	12
10	Hexagon screw M14X45	YW60144500000	18	YW60144500000	24
11	Right material fender	BH10213001110	1	BH10254001810	1
12	Small nut	YW64602000000	2	YW64602000000	2
13	Right bearing base	BH10213001310	1	BH10254002310	1
14	Right bearing	YW11021100000	1	YW11021100000	1
15	Big pulley SPA315-4-3020-55 with sleeve	YW30315400000	1	YW30315400000	1

No.	Name	SG-2950EB		SG-3260EB	
		Part No.	Qua.	Part No.	Qua.
1	Pressing plate of fly wheel	-	1	-	1
2	Fly wheel	BH10295001610	1	BH10295001610	1
3	Left bearing	YW11021200800	1	YW11021200800	1
4	Left bearing base	BH10295001810	1	BW30326000710	1
5	Left material fender	BH10295000710	1	BH11326000110	1
6	Shaft	BH10295000610	1	BH10326000710	1
7	Flat key 18X11XL	BH10295001410	1	BH11326000310	1
8	Blade shaft	BH10295000810	5	BW30326001010	6
9	Rotating blade	YW41254000000	15	YW41254000000	18
10	Hexagon screw M14X45	YW60144500000	30	YW60144500000	36
11	Right material fender	BH10295001310	1	BH11326000210	1
12	Small nut	YW64642000000	2	YW64642000000	2
13	Right bearing base	BH10295001810	1	BW30326000710	1
14	Right bearing	YW11021200800	1	YW11021200800	1
15	Big pulley SPA315-4-3020-55 with sleeve	YW30315400200	1	YW30335400000	1
No.	Name	SG-4880EB			
		Part No.	Qua.		
1	Pressing plate of fly wheel	-	1		
2	Fly wheel	BH10488000610	1		
3	Left bearing	YW11021500800	1		
4	Left bearing base	BW30488002510	1		
5	Left material fender	BH10488001810	1		
6	Shaft	BH10488001710	1		
7	Flat key 18X11XL	BH10488002010	1		
8	Blade shaft	BW30488001610	8		
9	Rotating blade	YW42488000700	24		
10	Hexagon screw M14X45	YW60145000100	48		
11	Right material fender	BH10488001910	1		
12	Small nut	YW64852000000	2		
13	Right bearing base	BW30488002510	1		
14	Right bearing	YW11021500800	1		

15	Big pulley SPA315-4-3020-55 with sleeve	YW30400500000	1		
----	--	---------------	---	--	--

Please confirm the version of manual before placing the purchase order to guarantee that the item number of the spare part is in accordance with the real object.

2.4.9 Cutting Chamber Assembly 3 (SG-60110EB)

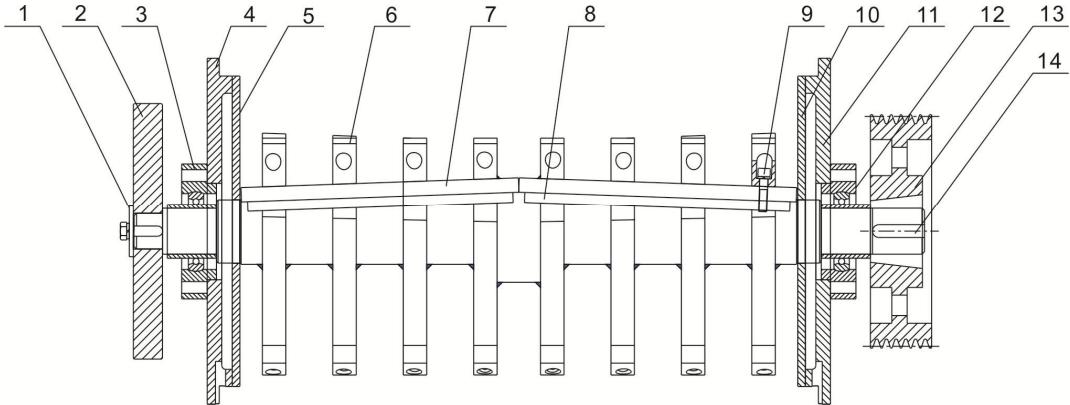

Note: The Arabic numerals of the parts refer to Parts List 2.3.10

Picture 2-9: Cutting Chamber Assembly 3

2.4.10 Parts List of Cutting Chamber Assembly 3(SG-60110EB)

Table 2-5: Parts List of Cutting Chamber Assembly 3

No.	Name	SG-60110EB	
		Part No.	Qua.
1	Pressing plate of fly wheel		-
2	Fly wheel	BH10488000610	1
3	Left bearing	YW11021800100	1
4	Left bearing base		1
5	Left material fender		1
6	Blade rest shaft		1
7	Rotating blade	YW41601100100	6
8	Pressing plate of rotating blade		6
9	Inner hexagon cylindrical screw	YW61167000000	24
10	Right material fender	-	1
11	Right bearing base	-	1
12	Right bearing	YW11021800100	1
13	Big pulley SPA450-6-4040-90 with sleeve	YW30450600000	10
14	Flat key	-	1

Please confirm the version of manual before placing the purchase order to guarantee that the item number of the spare part is in accordance with the real object.

2.4.11 Screen

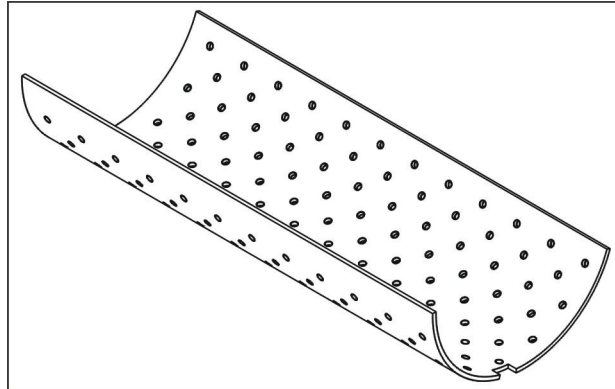

Picture 2-10: Screen

2.4.12 Screen Parts List

Table 2-6: Screen Parts List

Name	SG-2130EB		SG-2540EB	
	Part No.	Quantity	Part No.	Quantity
Screen 8mm	BL54213000020	1	BL54254000040	1
Name	SG-2950EB		SG-3260EB	
	Part No.	Quantity	Part No.	Quantity
Screen 8mm	BL54295000020	1	BL54326000420	1
Name	SG-4880EB		SG-60110EB	
	Part No.	Quantity	Part No.	Quantity
Screen 12mm	BL54488000920	1	-	1

Please confirm the version of manual before placing the purchase order to guarantee that the item number of the spare part is in accordance with the real object.

2.4.13 Shield Assembly

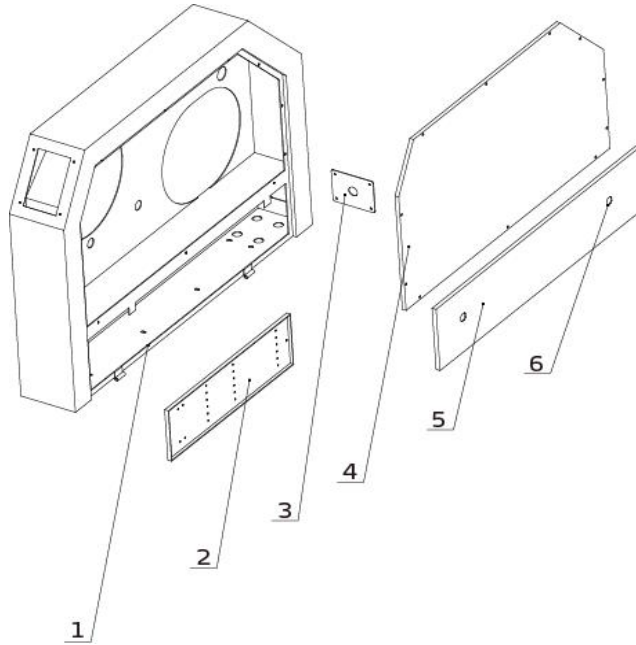

Note: The Arabic numerals of the parts refer to Parts List 2.3.14

Picture 2-11: Cover Assembly

2.4.14 Parts List of Shield Assembly

Table 2-7: Parts List of Shield Assembly

No.	Name	SG-21EB/25EB/29EB/32EB/60EB	
		Part No.	Qua.
1	Right shell	-	1
2	Wiring board	-	1
3	Fixing plate of wire clamp	BL5021000020	1
4	Upper cover plate of shell	-	1
5	Lower cover plate of shell	-	1
6	Long door lock	YW00000000100	2

Please confirm the version of manual before placing the purchase order to guarantee that the item number of the spare part is in accordance with the real object.

2.4.15 Collection Box Assembly

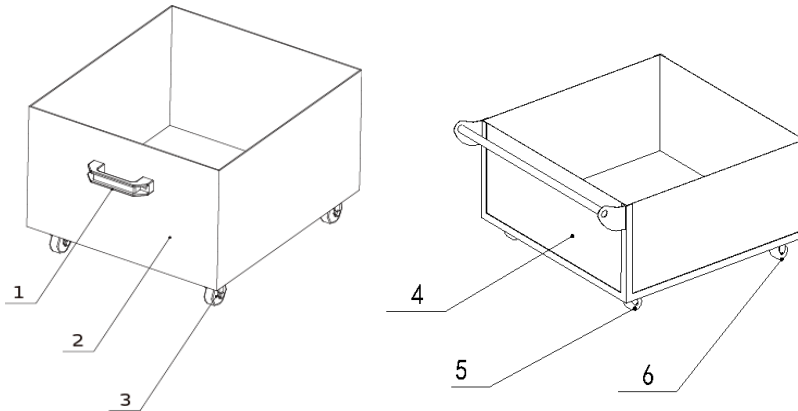

Note: The Arabic numerals of the parts refer to Parts List 2.3.16

Picture 2-12: Collection Box Assembly

2.4.16 Parts List of Collection Box Assembly

Table 2-8: Parts List of Collection Box Assembly

No.	Name	SG-21EB/25EB/29EB/32EB	
		Part No.	Qua.
1	Aluminum square handle	BW20012000140	1
2	Collection box	-	1
3	Movable castor 2"	YW03000200000	4
No.	Name	SG-48EB	
		Part No.	Qua.
1	Aluminum square handle	BW20012000140	1
2	Collection box	-	1
3	Movable castor 3"	YW03000300200	4
No.	Name	SG-60EB	
		Part No.	Qua.
4	Collection box	-	1
5	Fixed castor 3"	YW03000300500	2
6	Movable castor 3"	YW03000300600	2

Please confirm the version of manual before placing the purchase order to guarantee that the item number of the spare part is in accordance with the real object.

2.4.17 Special Screen

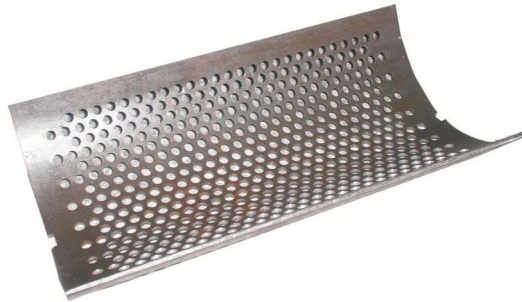

Picture 2-13: Special Screen

Dia. (mm)	Part No.			
	SG-2130EB	SG-2540EB	SG-2950EB	SG-3260EB
Φ6	BL54213001520	BL54254000620	BL54295006720	BL54326000720
Φ10	BL54213001620	BL54254000720	BL54295000620	BL54326000520
Φ12	BL54213001720	BL54254000820	BL54295000720	BL54326000620
Φ16	BL54213000320	BL54254000320	BL54295000320	BL54326000320
Dia. (mm)	Part No.			
	SG-4880EB		SG-60110EB	
Φ10	BL54488001520		-	
Φ14	BL54488001620		-	

Please confirm the version of manual before placing the purchase order to guarantee that the item number of the spare part is in accordance with the real object.

2.4.18 Cutter

Material	International Code		
	China	USA	Japan
SKD11	Cr12MoV	D2	SKD11

2.5 Wiring Diagram

2.5.1 Main Circuit and Control Circuit Diagram(SG-2130EB)(400V)

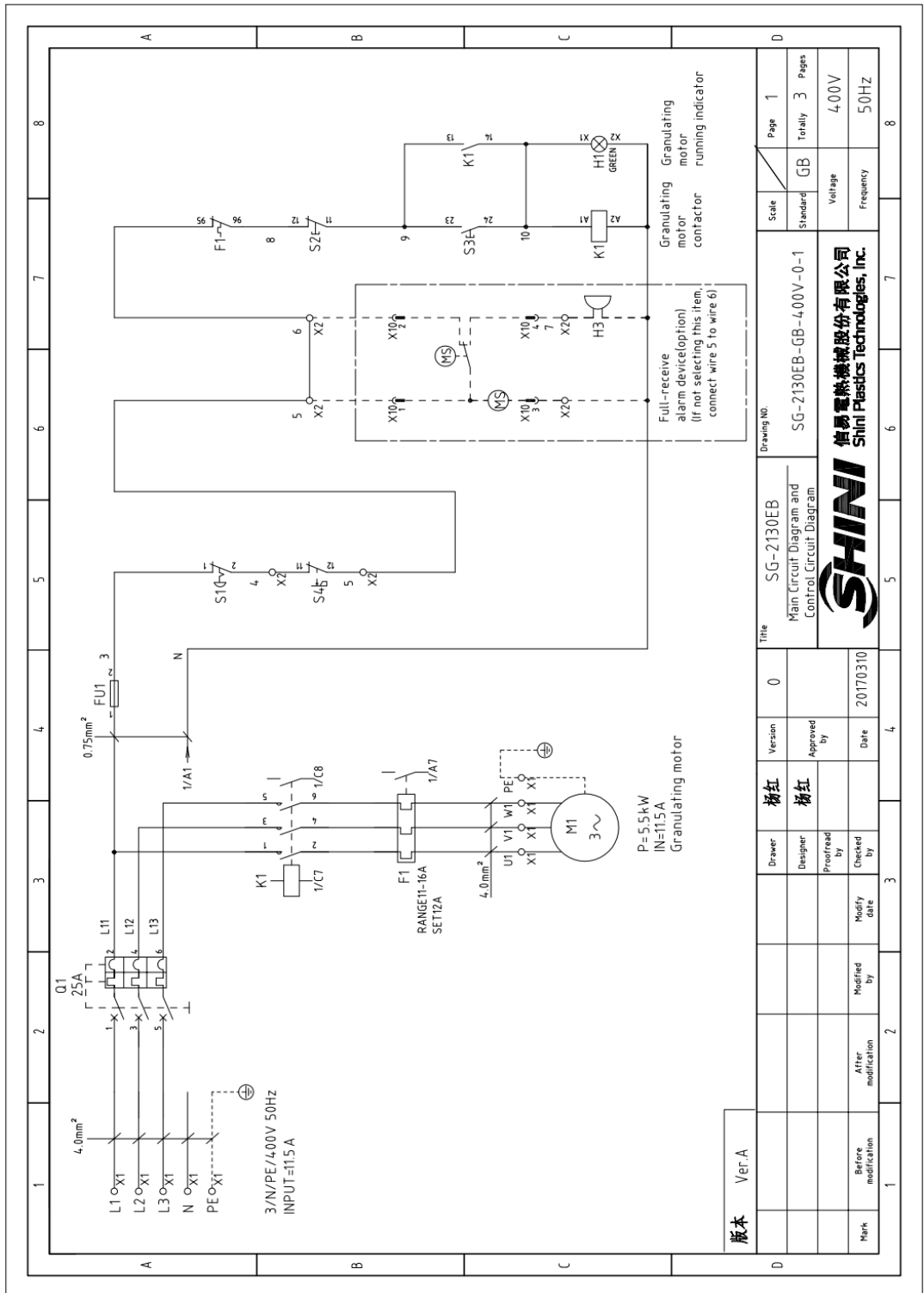

Drawing No.		Scale		Page	
SG-2130EB		Standard		1	
Main Circuit Diagram and Control Circuit Diagram		GB		3	
Title		Standard		Totally	
SG-2130EB-GB-400V-0-1		Voltage		400V	
SHINI 德昂電熱機械股份有限公司 Shini Plastics Technologies, Inc.		Frequency		50Hz	
Version	0	Page	8		
Drawer	楊紅	Standard	GB		
Designer	楊紅	Voltage	400V		
Proofread by		Frequency	50Hz		
Checked by		Date			
Modified by		20170310			
Mark	Before modification	Date			
	After modification	Date			

2.5.2 Electrical Components Layout(SG-2130EB) (400V)

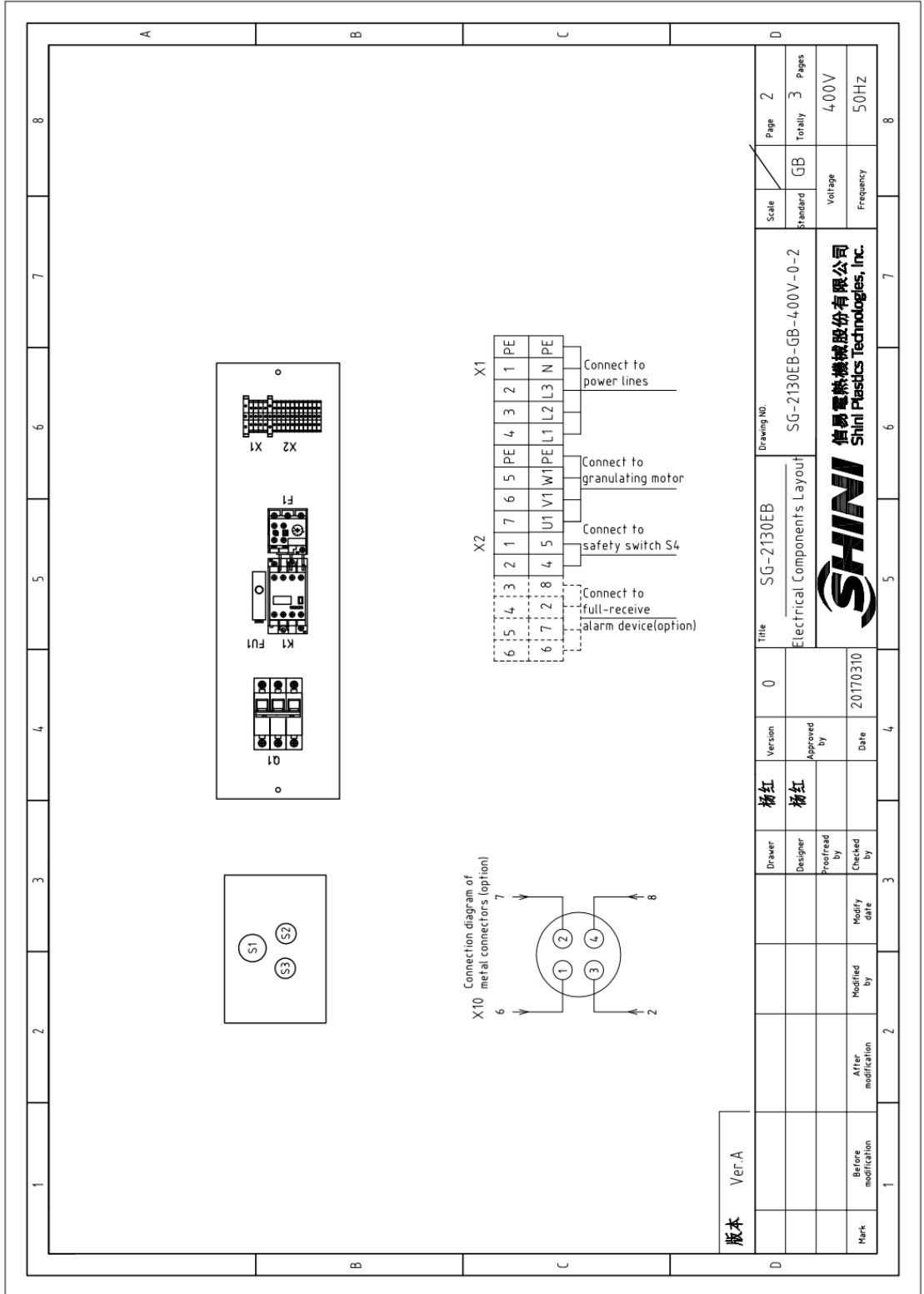

2.5.3 Main Circuit and Control Circuit Diagram(SG-2540EB) (400V)

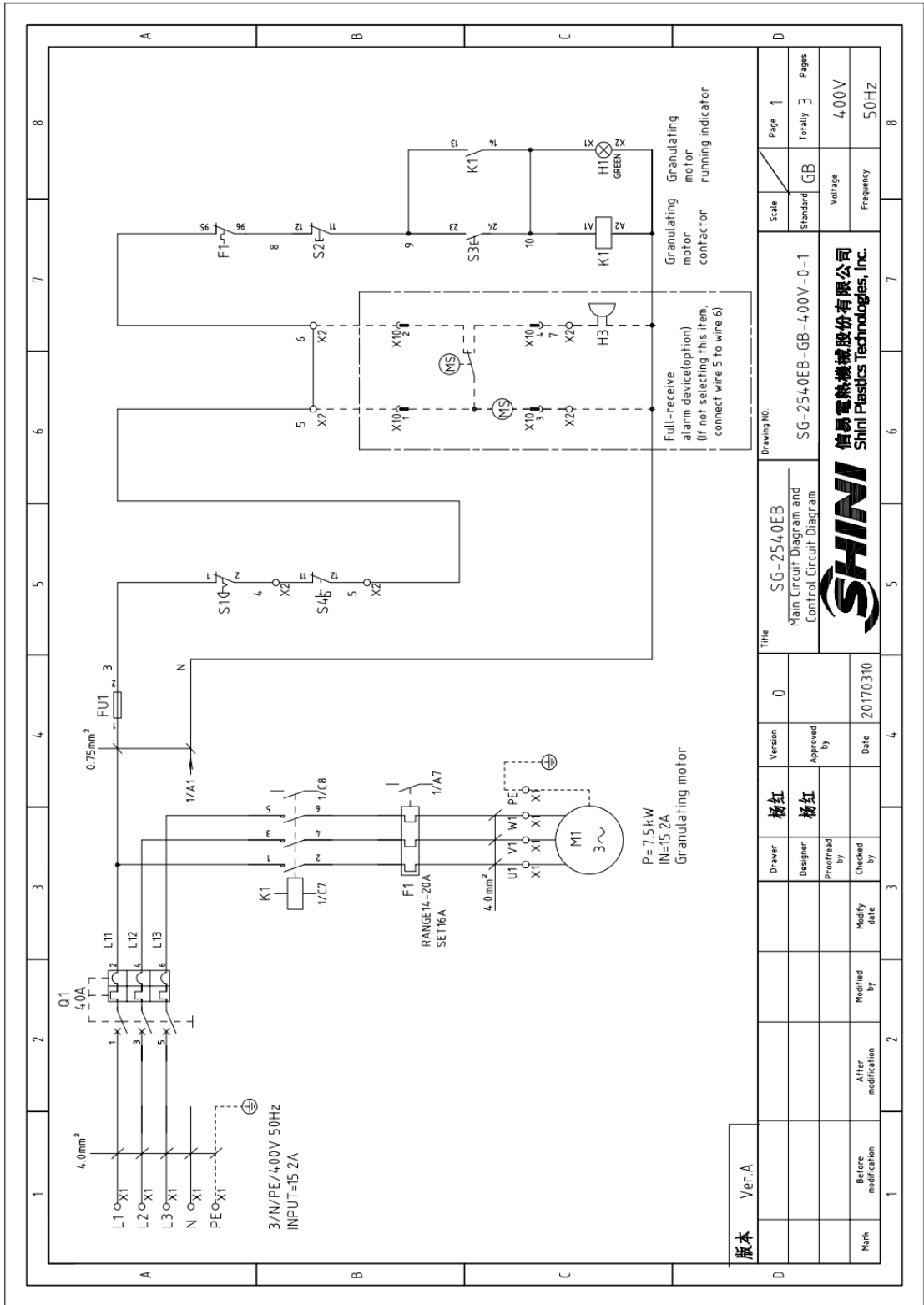

Scale	Standard	Page 1	Totally 3
Standard	GB	Voltage	4.00V
		Frequency	50Hz

Title		Drawing No.	
SG-2540EB Main Circuit Diagram and Control Circuit Diagram		SG-2540EB-GB-400V-0-1	
Designer	杨红	Version	0
Approved by	杨红	Checked by	
Checked by		Date	20170310
Modify date		Modify date	
After modification		After modification	
Before modification		Before modification	

SHINI
 德昂电热机械股份有限公司
 Shini Plastics Technologies, Inc.

2.5.4 Electrical Components Layout(SG-2540EB) (400V)

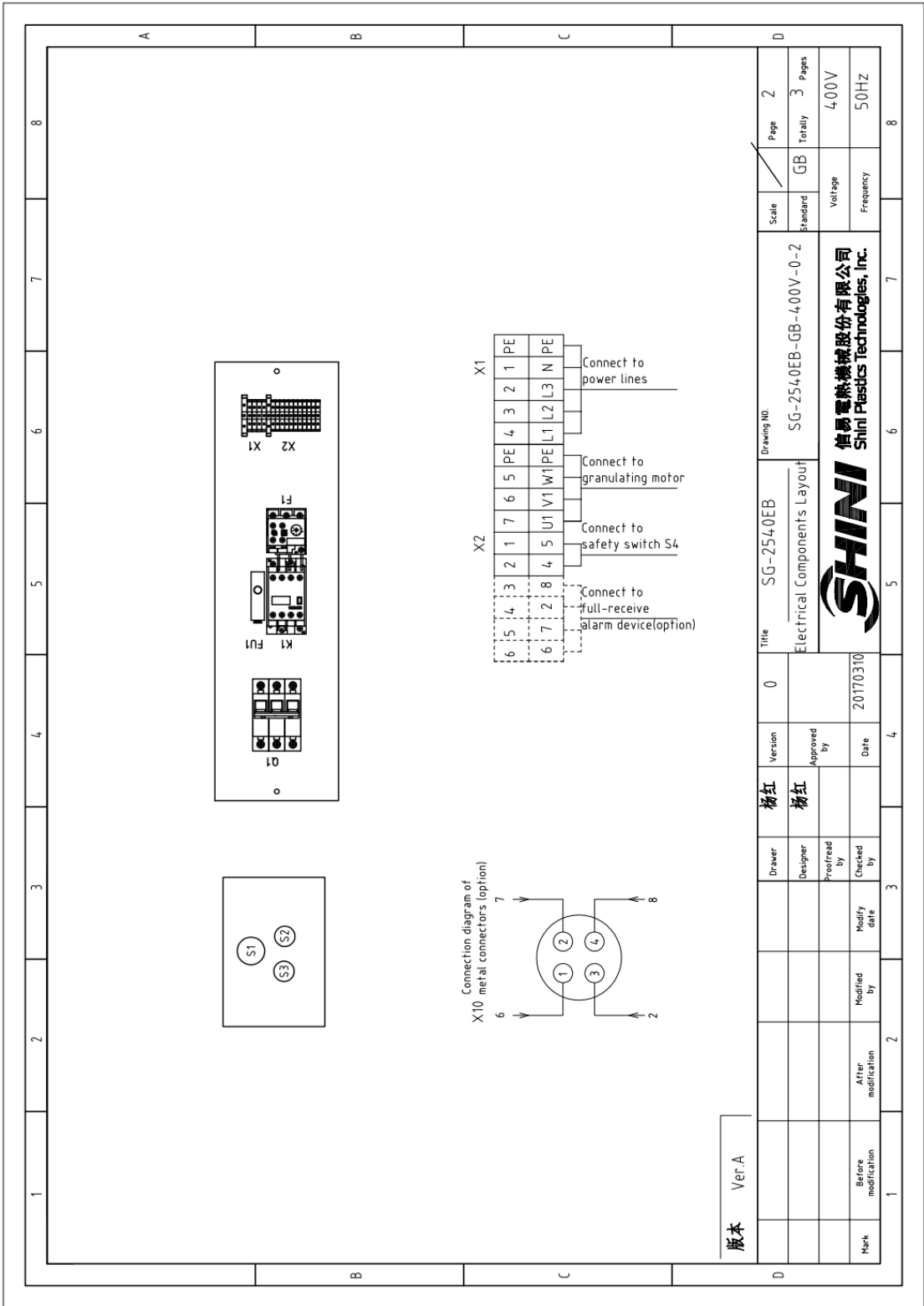

2.5.5 Main Circuit and Control Circuit Diagram(SG-2950EB) (400V)

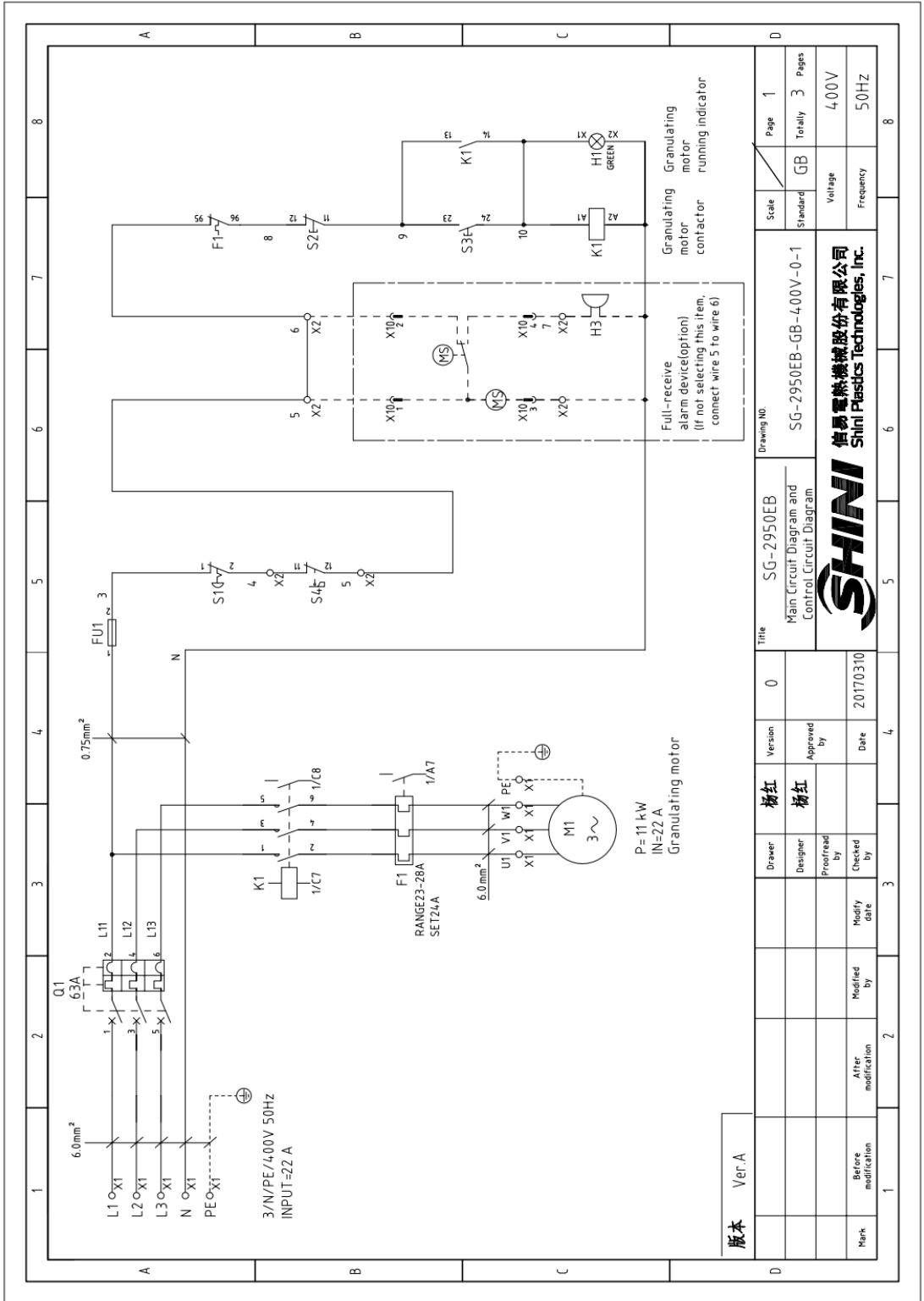

Drawing No.		Scale		Page 1	
SG-2950EB		Standard		Totally 3 Pages	
Main Circuit Diagram and Control Circuit Diagram		GB		Voltage 400V	
SHINI 神戶電機株式会社 Shini Plastics Technologies, Inc.		Frequency		50Hz	
Version	0	Standard	GB	Frequency	50Hz
Drawer	杨红	Standard	GB	Frequency	50Hz
Designer	杨红	Standard	GB	Frequency	50Hz
Proofread by		Standard	GB	Frequency	50Hz
Checked by		Standard	GB	Frequency	50Hz
Modify date		Standard	GB	Frequency	50Hz
After modification		Standard	GB	Frequency	50Hz
Before modification		Standard	GB	Frequency	50Hz
Mark		Standard	GB	Frequency	50Hz
Date	20170310	Standard	GB	Frequency	50Hz
Version	0	Standard	GB	Frequency	50Hz
Approved by		Standard	GB	Frequency	50Hz
Checked by		Standard	GB	Frequency	50Hz
Modify date		Standard	GB	Frequency	50Hz
After modification		Standard	GB	Frequency	50Hz
Before modification		Standard	GB	Frequency	50Hz
Mark		Standard	GB	Frequency	50Hz

2.5.6 Electrical Components Layout(SG-2950EB) (400V)

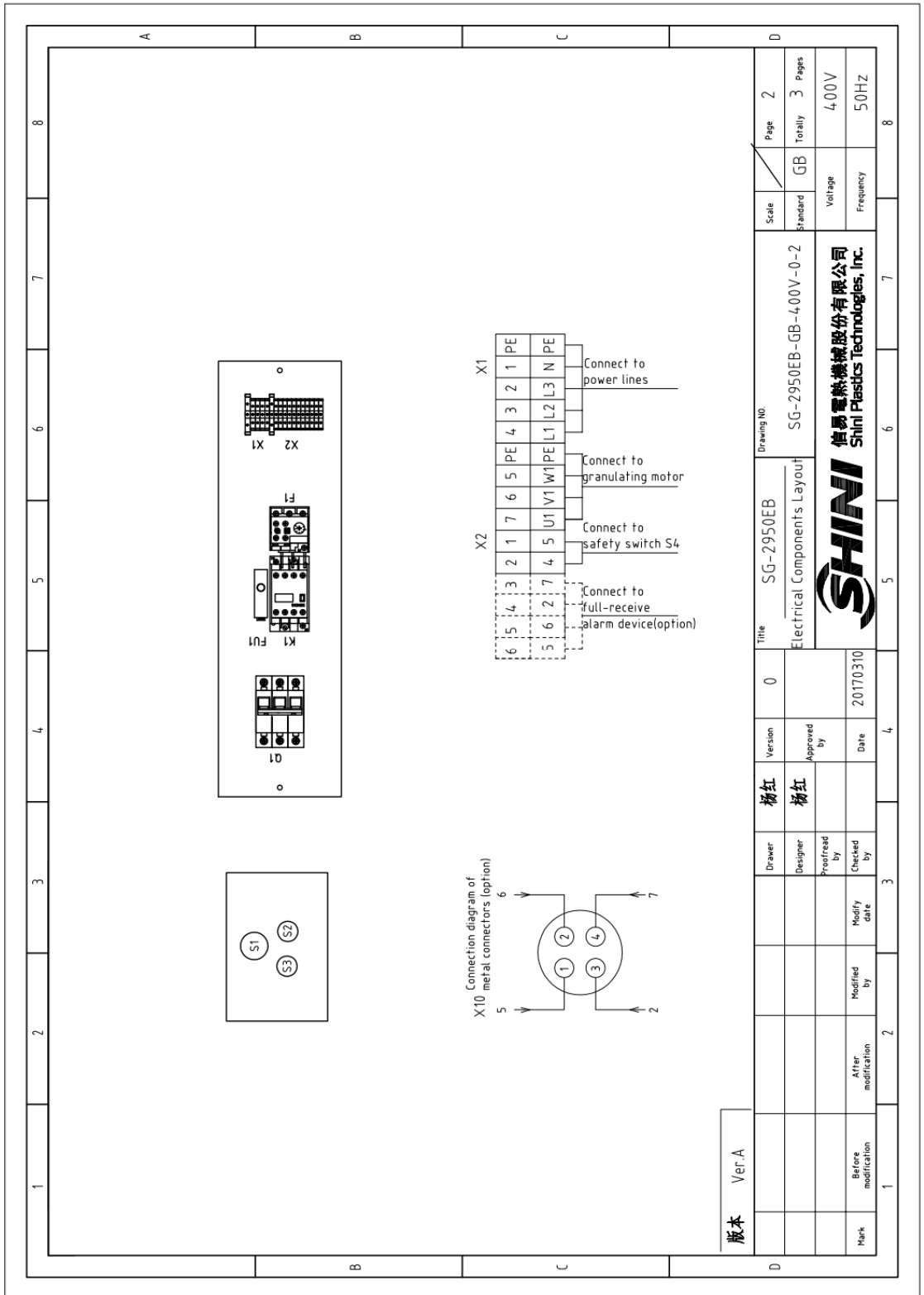

2.5.7 Main Circuit (SG-3260EB) (400V)

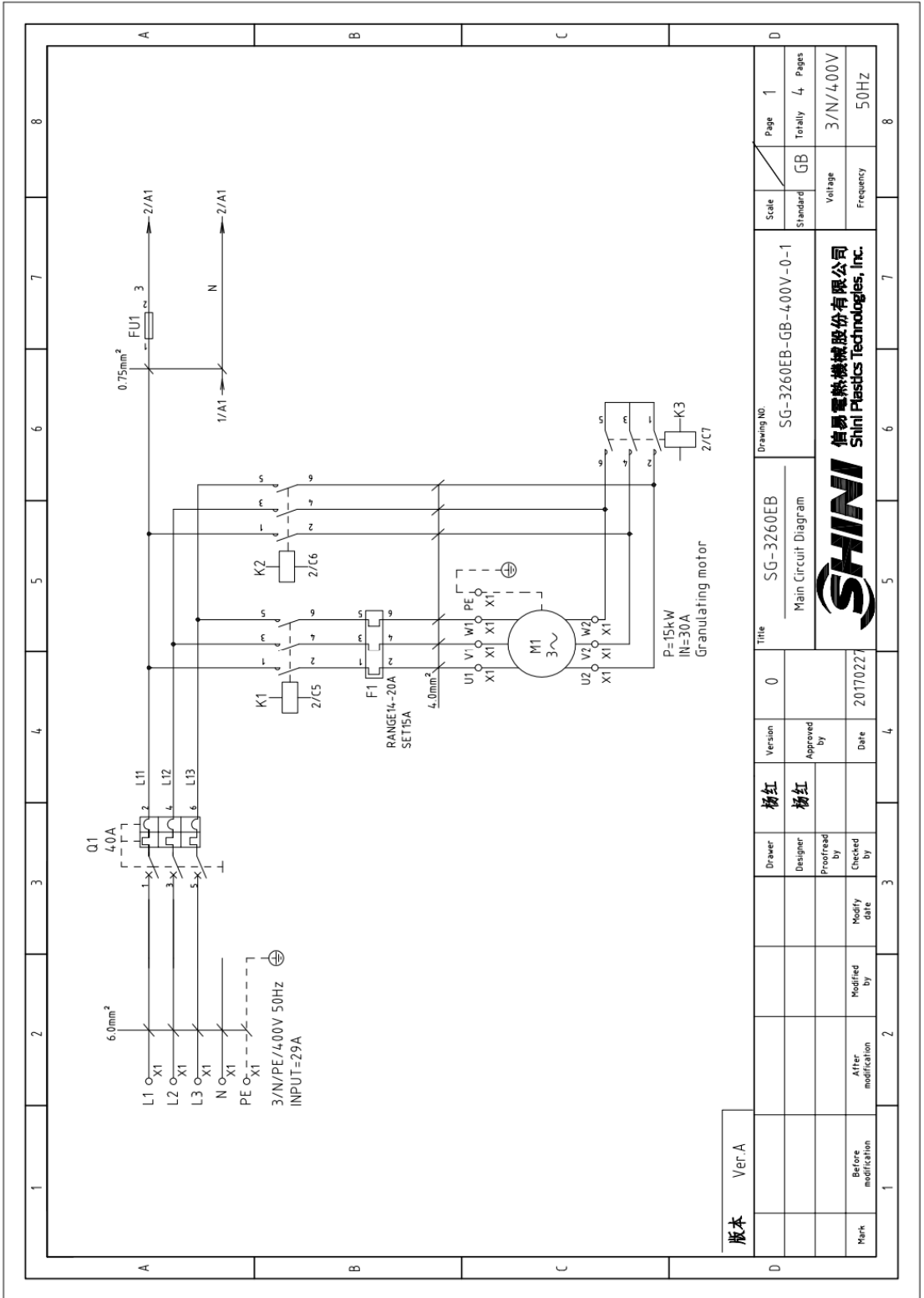

2.5.8 Control Circuit Diagram(SG-3260EB) (400V)

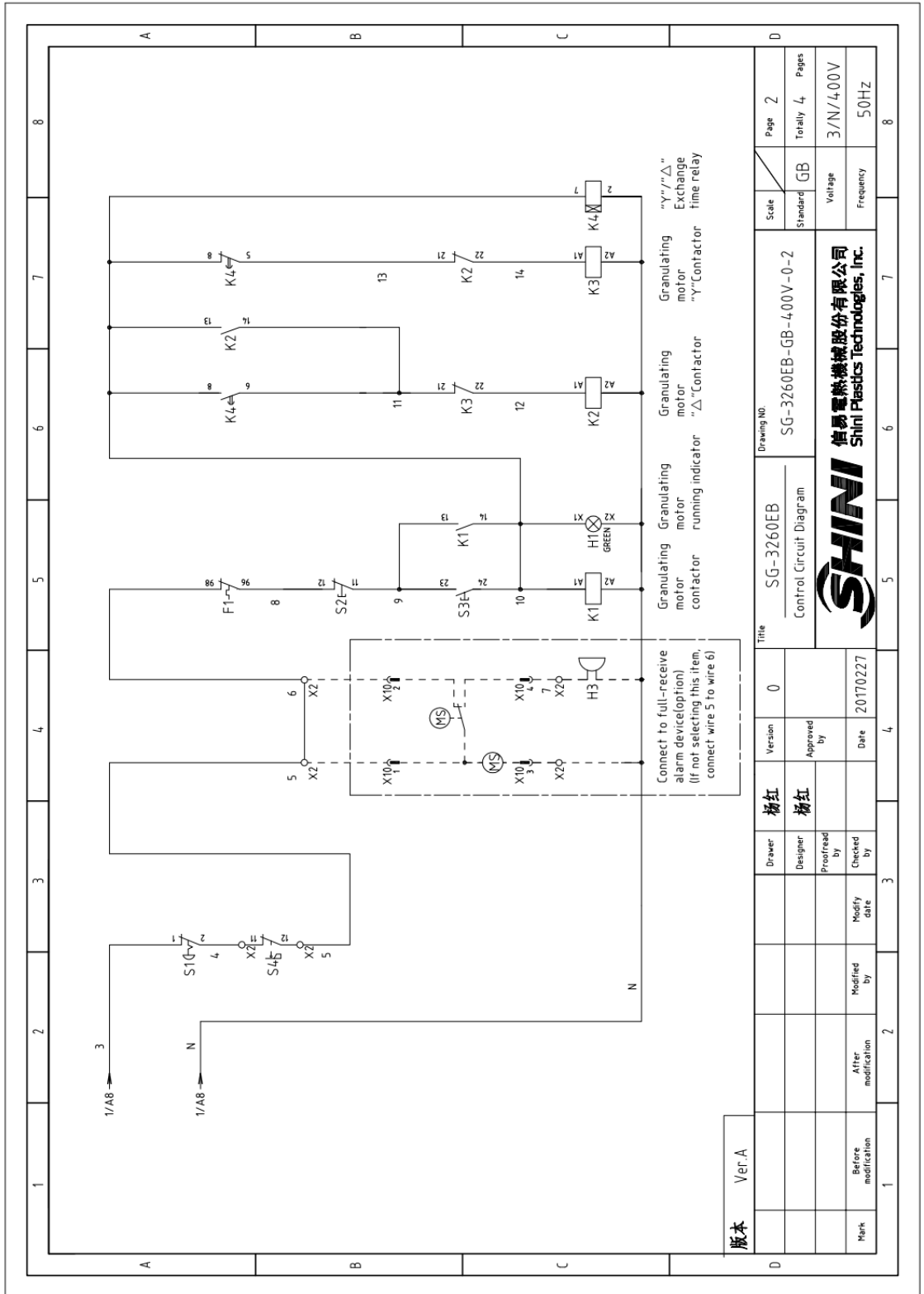

版本 Ver-A		Drawing No. SG-3260EB-GB-4.00V-0-2		Scale	Page 2
Title SG-3260EB Control Circuit Diagram		Standard GB		Totally 4 Pages	
Version 0		Voltage 3/N/4,00V		Frequency 50Hz	
Designer 杨红		Checked by		Date 20170227	
Proofread by		Modified by		Modify date	
Checked by		After modification		2	
Mark		Before modification		3	
				4	
				5	
				6	
				7	
				8	



2.5.9 Electrical Components Layout(SG-3260EB) (400V)

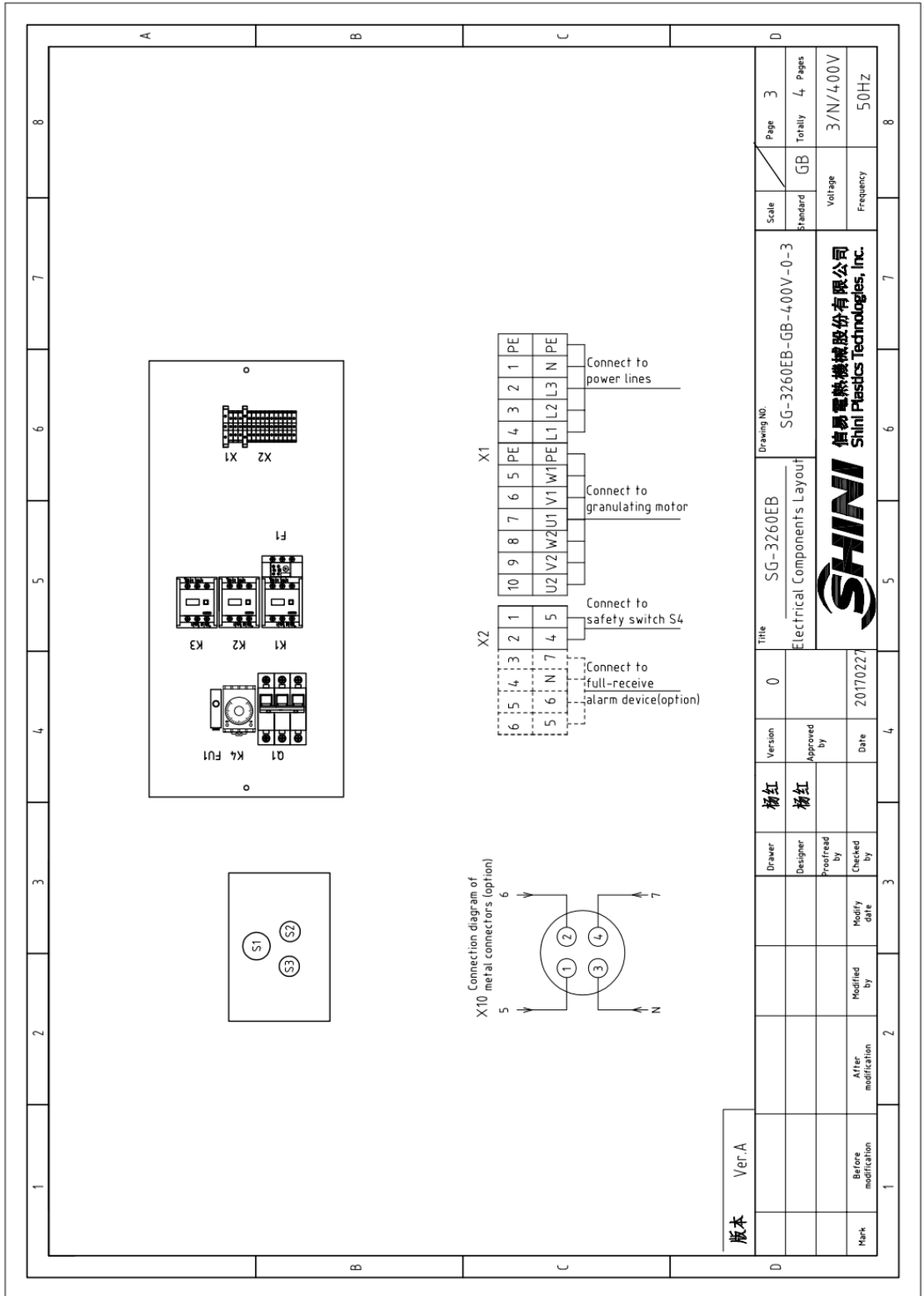

2.5.10 Main Circuit (SG-4880EB) (400V)

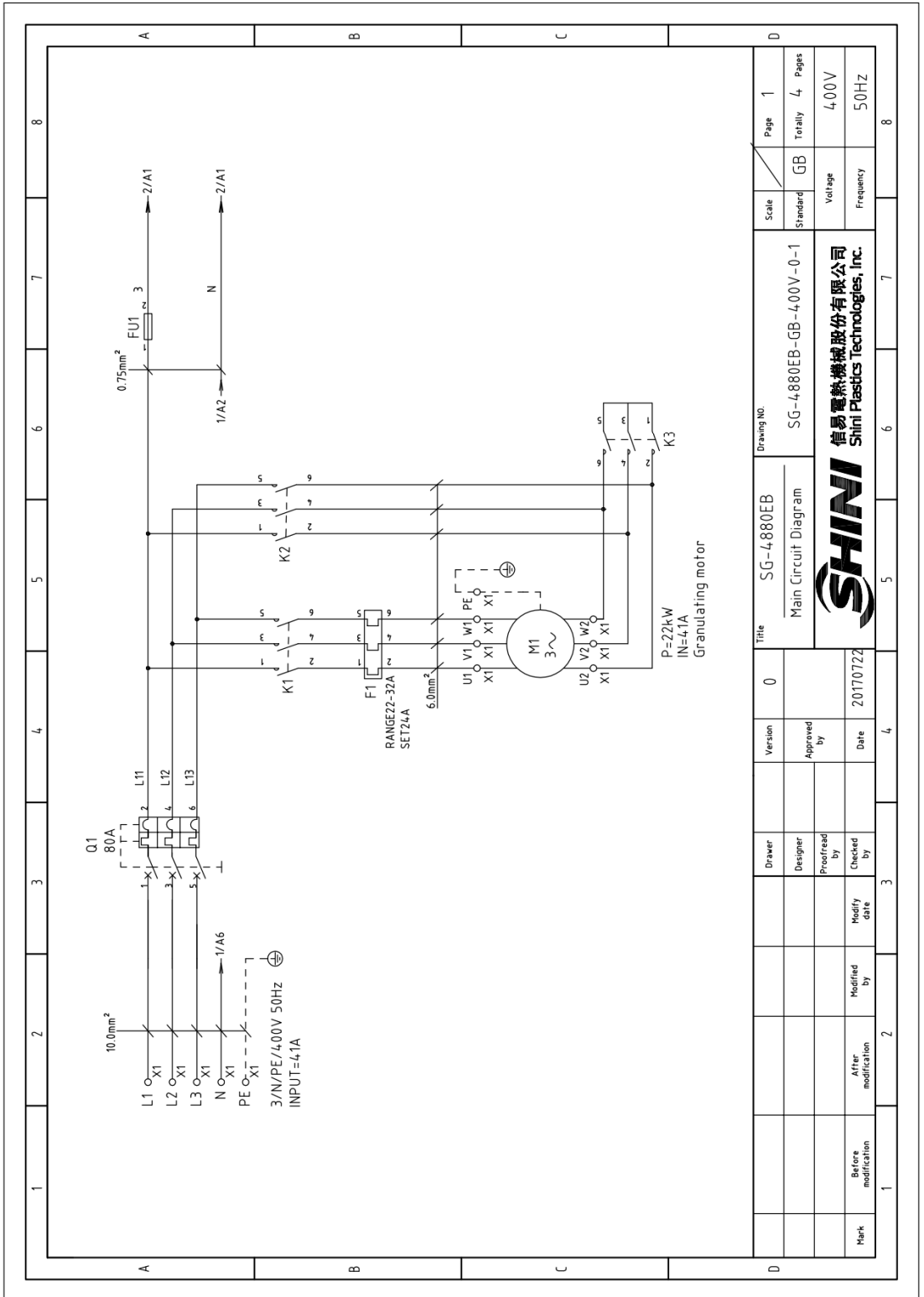

Mark	Before modification	After modification	Modified by	Modify date	Checked by	Date	Approved by	Version	0	Title	SG-4880EB Main Circuit Diagram	Drawing NO.	SG-4880EB-GB-400V-0-1	Scale	GB	Page	1
						20170722										Totally	4
																Voltage	400V
																Frequency	50Hz

SHINI
信易電熱機械股份有限公司
Shini Plastics Technologies, Inc.

2.5.11 Control Circuit Diagram (SG-4880EB) (400V)

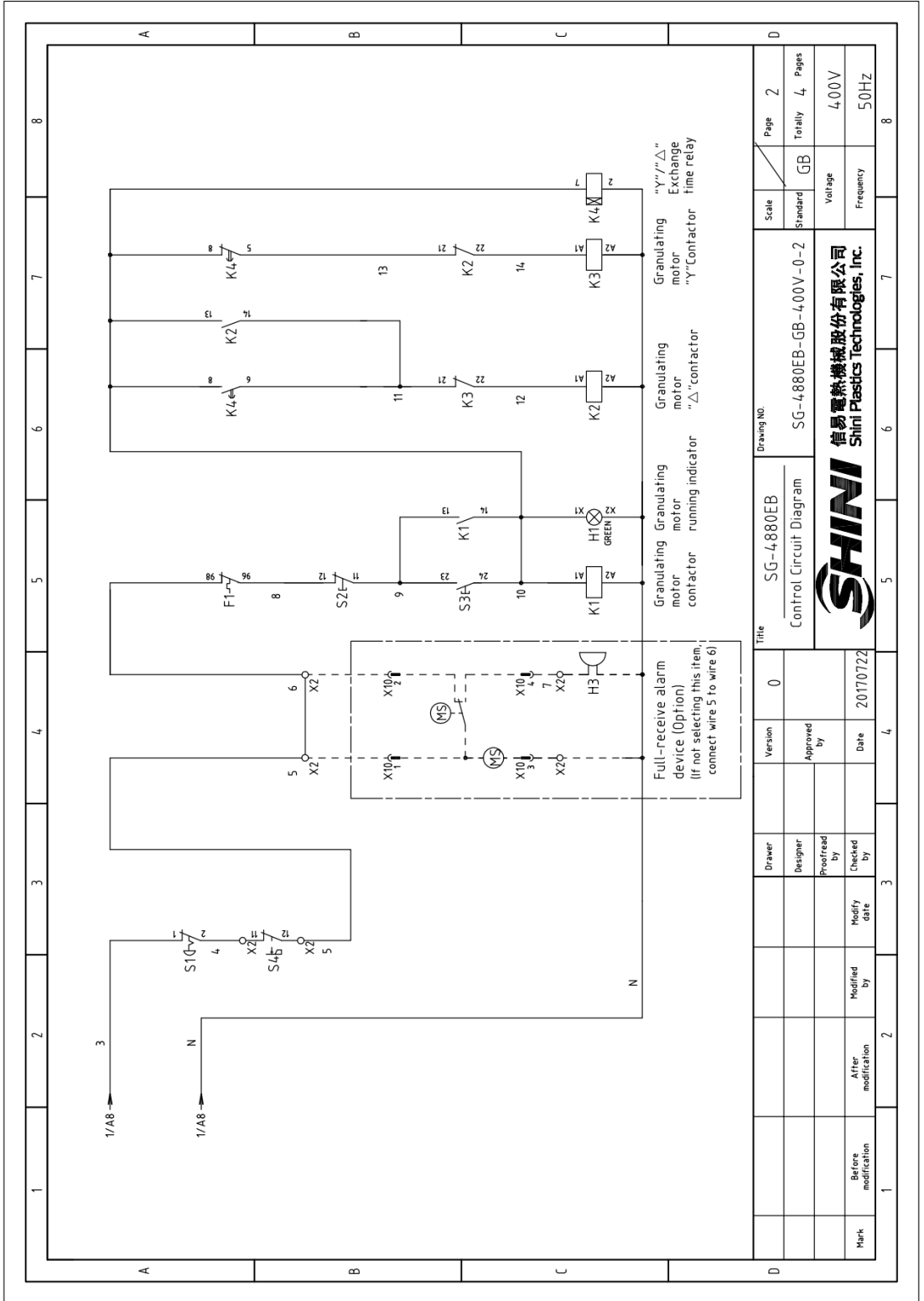

2.5.12 Electrical Components Layout (SG-4880EB) (400V)

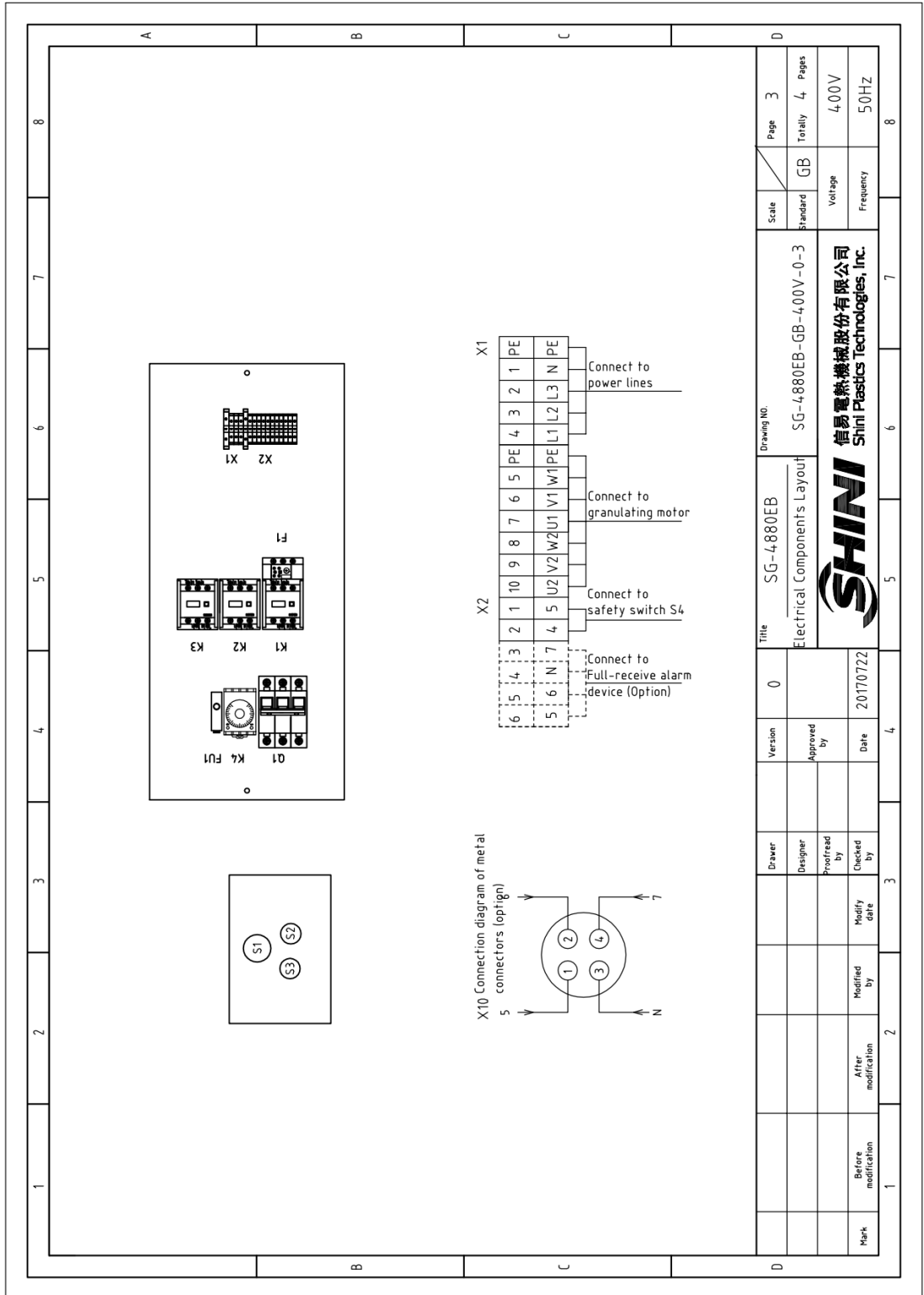

2.5.13 Main Circuit (SG-60110EB) (400V)

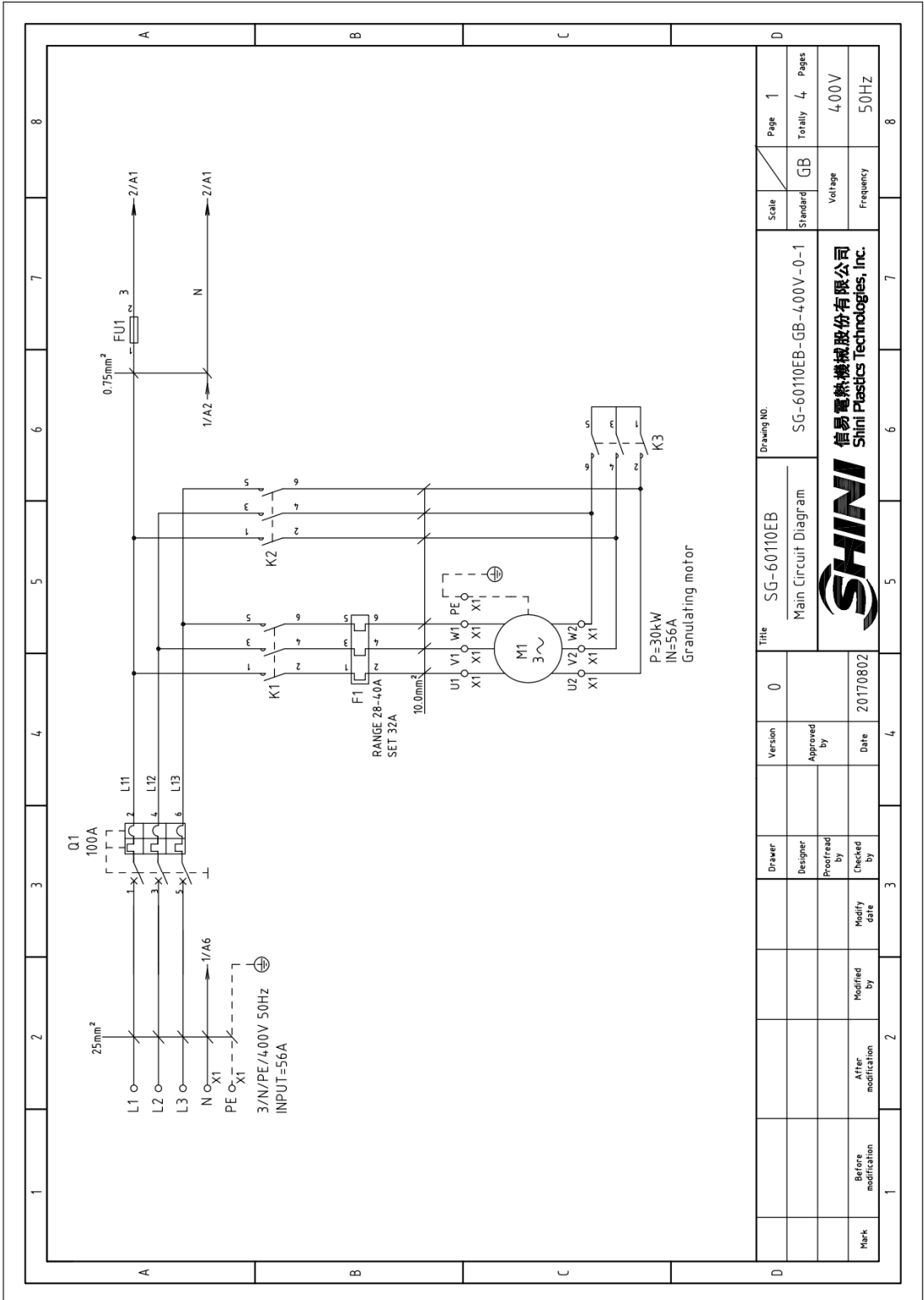

2.5.14 Control Circuit Diagram (SG-60110EB) (400V)

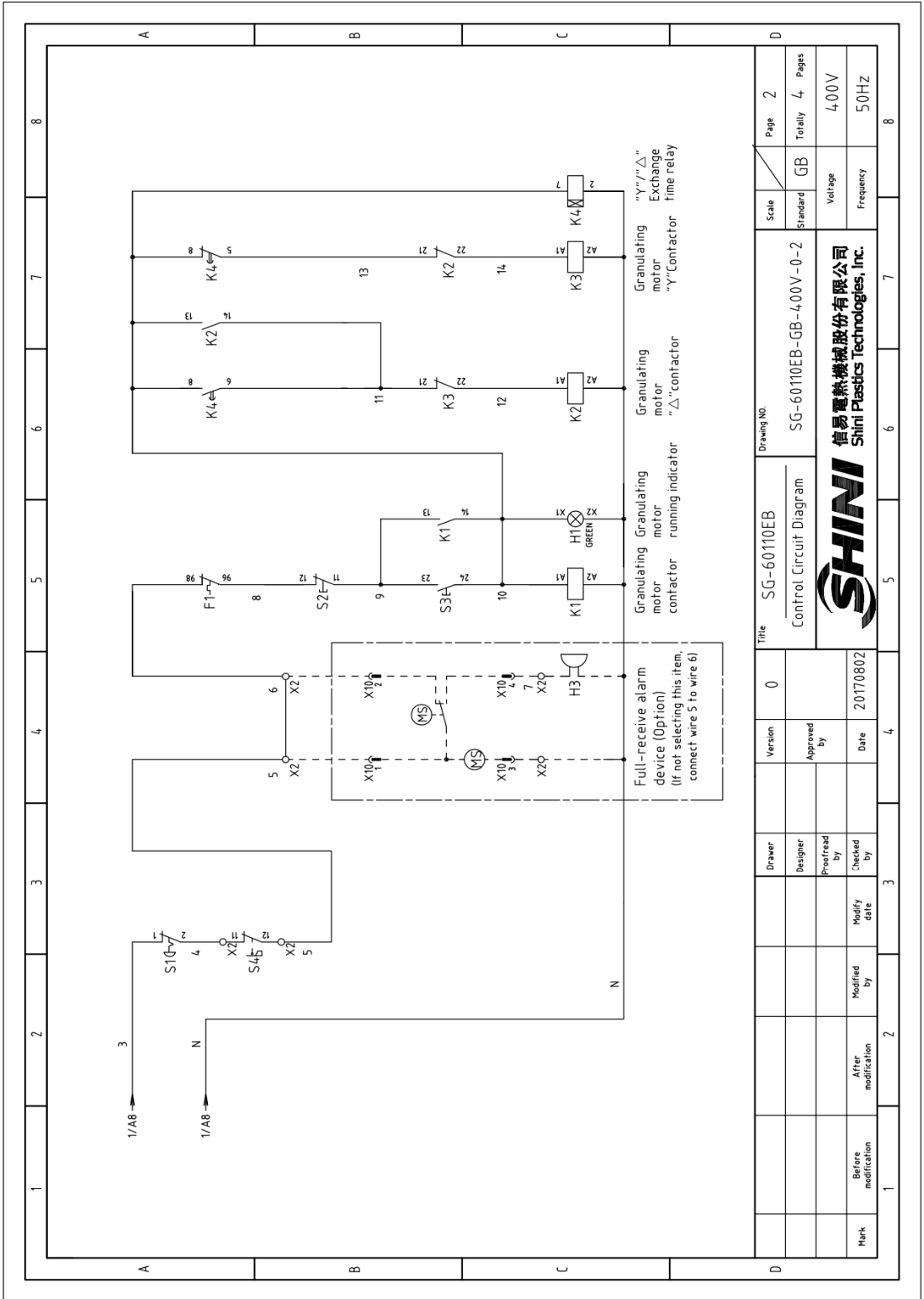

2.5.15 Electrical Components Layout (SG-60110EB) (400V)

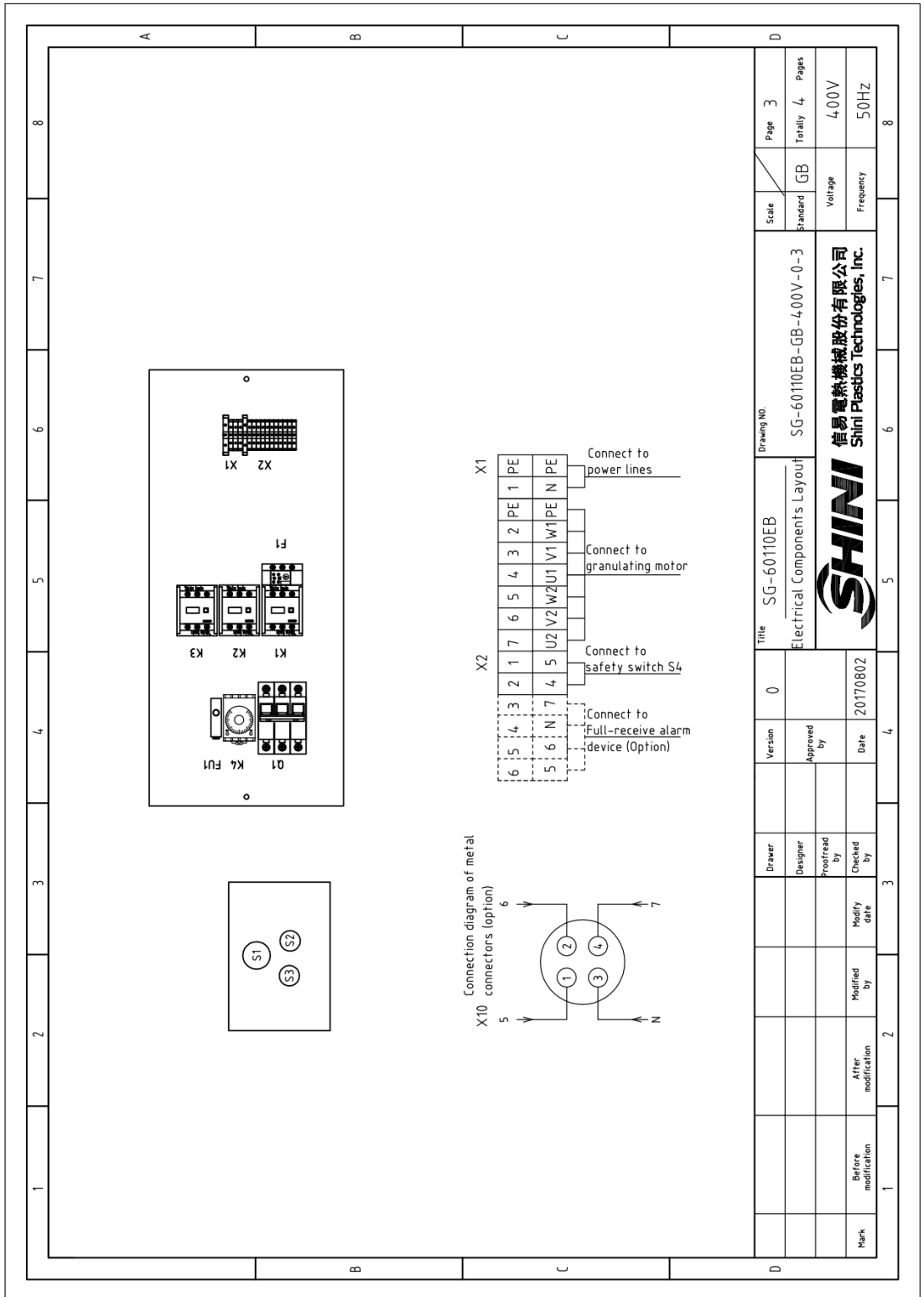

2.5.16 Electrical Components List(400V)

Table 2-9: Electrical Components List(SG-2130 EB) (400V)

NO.	Symbol	Name	Specification	Part NO.	Note
1	Q1	Circuit braker *	25A	YE40302503000	-
2	K1	Contactora**	220VAC 50/60Hz	YE00601800000	-
3	F1	Thermo overload relay	11~16A	YE01611640000	-
4	FU1	Fuse **	2A	YE41001000000	-
5	X1	Terminal board	4.0mm ²	YE60002503200	-
6			4.0mm ² PE	YE60002503500	-
7	X2	Terminal board	2.5mm ²	YE61250040000	-
8			2.5mm ²	YE61250040000	Option
9	H3	Buzzer	220VAC	YE84222000000	Option
10	S1	Emergency stop button	1NC	YE11411000000	-
11	S2	Stop button	1NC	YE11113100000	-
12	S3,H1	Start button	1NO	YE11100100000	-
13	S4	Safety switch	AZ-15	YE16147600100	-
14	MS	Materia level switch	220VAC	YE15000200100	Option
15	X10	Metal joint	4P	YE68025400000	Option
16			4P	YE68025400100	Option
17	M1	Granulating motor	400V 50Hz	-	-
18		Cable 4.0x5Cx4M	BA	BE51040500250	-

* means possible broken parts. ** means easy broken part. and spare backup is suggested.

Please confirm the version of manual before placing the purchase order to guarantee that the item number of the spare part is in accordance with the real object.

Table 2-10: Electrical Components List(SG-2540 EB) (400V)

NO.	Symbol	Name	Specification	Part NO.	Note
1	Q1	Circuit braker *	40A	YE40304003000	-
2	K1	Contactora **	220VAC 50/60Hz	YE00602622000	-
3	F1	Thermo overload relay	14~20A	YE01260140000	-
4	FU1	Fuse **	2A	YE41001000000	-
5	X1	Terminal board	4.0mm ²	YE61040000000	-
6			4.0mm ² PE	YE61043500000	-
7	X2	Terminal board	2.5mm ²	YE61250040000	-
8			2.5mm ²	YE61250040000	Option
9	H3	Buzzer	220VAC	YE84222000000	Option
10	S1	Emergency stop button	1NC	YE11411000000	-
11	S2	Stop button	1NC	YE11113100000	-
12	S3,H1	Start button	1NO	YE11100100000	-

13	S4	Safety switch	AZ-15	YE16147600100	-
14	MS	Materia level switch	220VAC	YE15000200100	Option
15	X10	Metal joint	4P	YE68025400000	Option
16	-	-	4P	YE68025400100	Option
17	M1	Granulating motor	400V 50Hz	-	-
18		Cable 4.0x5Cx4M	BA	BE51040500250	-

* means possible broken parts. ** means easy broken part. and spare backup is suggested.

Please confirm the version of manual before placing the purchase order to guarantee that the item number of the spare part is in accordance with the real object.

Table 2-11: Electrical Components List (SG-2950 EB) (400V)

NO.	Symbol	Name	Specification	Part NO.	Note
1	Q1	Circuit braker *	63A	YE40306303000	-
2	K1	Contactor **	220VAC 50/60Hz	YE00602722000	-
3	F1	Thermo overload relay	23~28A	YE01612620000	-
4	FU1	Fuse **	2A	YE41001000000	-
5	X1	Terminal board	6.0mm ²	YE60000603200	-
6			6.0mm ² PE	YE60000603500	-
7	X2	Terminal board	2.5mm ²	YE60002503200	-
8			2.5mm ² PE	YE60002503200	Option
9	H3	Buzzer	220VAC	YE84222000000	Option
10	S1	Emergency stop button	1NC	YE11411000000	-
11	S2	Stop button	1NC	YE11113100000	-
12	S3,H1	Start button	1NO	YE11100100000	-
13	S4	Safety switch	AZ-15	YE16147600100	-
14	MS	Materia level switch	220VAC	YE15000200100	Option
15	X10	Metal joint	4P	YE68025400000	Option
16			4P	YE68025400100	Option
17	M1	Granulating motor	400V 50Hz	-	-
18		Cable 6.0x5Cx5M	BA	BE51060500250	-

*means possible broken parts. ** means easy broken part. and spare backup is suggested.

Please confirm the version of manual before placing the purchase order to guarantee that the item number of the spare part is in accordance with the real object.

Table 2-12: Electrical Components List (SG-3260EB)(400V)

NO.	Symbol	Name	Specification	Part NO.	Note
1	Q1	Circuit braker *	40A	YE40304003000	-
2	K1 K2	Contactora **	220VAC 50/60Hz	YE00602822000	-
3	K3	Contactora **	220VAC 50/60Hz	YE00602722000	-
4	F1	Thermo overload relay	14-20A	YE01260140000	-
5	FU1	Fuse **	2A	YE41001000000	-
6	K4	Time relay	3S-60M 230VAC	YE86300300000	-
7	X1	Terminal board	6.0mm ²	YE60002503200	-
8			6.0mm ² PE	YE60002503400	-
9			4.0mm ²	YE60000403200	-
10			4.0mm ²	YE60000403500	-
11	X2	Terminal board	6.0mm ²	YE60000603200	-
12			6.0mm ² PE	YE60000603500	Option
13	H3	Buzzer	220VAC	YE84222000000	Option
14	S1	Emergency stop button	1NC	YE11411000000	-
15	S2	Stop button	1NC	YE11113100000	-
16	S3,H1	Start button	1NO	YE11100100000	-
17	S4	Safety switch	AZ-15	YE16147600100	-
18	MS	Materia level switch	220VAC	YE15000200100	Option
19	X10	Metal joint	4P	YE68025400000	Option
20			4P	YE68025400100	Option
21	M1	Granulating motor	400V 50Hz	-	-

*means possible broken parts. ** means easy broken part. and spare backup is suggested.

Please confirm the version of manual before placing the purchase order to guarantee that the item number of the spare part is in accordance with the real object.

Table 2-13: Electrical Components List (SG-4880EB)(400V)

NO.	Symbol	Name	Specification	Part NO.	Note
1	Q1	Circuit braker *	80A	YE40308003000	-
2	K1 K2	Contactor **	220VAC 50/60Hz	YE00503600000	-
3	K3	Contactor **	220VAC 50/60Hz	YE00503500000	-
4		Auxiliary contactor	1NC	YE00592110100	
5		Auxiliary contactor	1NO	YE00592110000	
6	F1	Thermo overload relay	22-32A	YE01223200000	-
7	FU1	Fuse **	2A	YE41001000000	-
8	K4	Time relay	3S-60M 230VAC	YE86300300000	-
9	X1	Terminal board	10mm ²	YE60001003200	-
10			10mm ² PE	YE60001003500	-
11			6.0mm ²	YE60000603200	-
12			6.0mm ² PE	YE60000603500	-
13	X2	Terminal board	2.5mm ²	YE60002503200	-
14			2.5mm ²	YE60002503200	Option
15	H3	Buzzer	220VAC	YE84222000000	Option
16	S1	Emergency stop button	1NC	YE11411000000	-
17	S2	Stop button	1NC	YE11113100000	-
18	S3,H1	Start button	1NO	YE11100100000	-
19	S4	Safety switch	AZ-15	YE16147600100	-
20	MS	Materia level switch	220VAC	YE15000200100	Option
21	X10	Metal joint	4P	YE68025400000	Option
22			4P	YE68025400100	Option
23	M1	Granulating motor	400V 50Hz	-	-
24		Cable 10.0x5Cx5M	BA	BE51105000150	

*means possible broken parts. ** means easy broken part. and spare backup is suggested.

Please confirm the version of manual before placing the purchase order to guarantee that the item number of the spare part is in accordance with the real object.

Table 2-14: Electrical Components List (SG-60110EB)(400V)

NO.	Symbol	Name	Specification	Part NO.	Note
1	Q1	Circuit braker *	100A	YE40310003000	-
2	K1 K2	Contactor **	220VAC 50/60Hz	YE00503600000	-
3	K3	Contactor **	220VAC 50/60Hz	YE00503500000	-
4		Auxiliary contactor	1NC	YE00592110100	
5		Auxiliary contactor	1NO	YE00592110000	
6	F1	Thermo overload relay	28-40A	YE01513600100	-
7	FU1	Fuse **	2A	YE41001000000	-
8	K4	Time relay	3S-60M 230VAC	YE86300300000	-
9	X1	Terminal board	35mm ²	YE60003503200	-
10			35mm ² PE	YE60003503500	-
11			10.0mm ²	YE60001003200	-
12			10.0mm ² PE	YE60001003500	-
13	X2	Terminal board	2.5mm ²	YE61250040000	-
14			2.5mm ²	YE61250040000	Option
15	H3	Buzzer	220VAC	YE84222000000	Option
16	S1	Emergency stop button	1NC	YE11411000000	-
17	S2	Stop button	1NC	YE11113100000	-
18	S3,H1	Start button	1NO	YE11100100000	-
19	S4	Safety switch	AZ-15	YE16147600100	-
20	MS	Materia level switch	220VAC	YE15000200100	Option
21	X10	Metal joint	4P	YE68025400000	Option
22			4P	YE68025400100	Option
23	M1	Granulating motor	400V 50Hz	-	-

*means possible broken parts. ** means easy broken part. and spare backup is suggested.

Please confirm the version of manual before placing the purchase order to guarantee that the item number of the spare part is in accordance with the real object.

2.5.17 Main Circuit and Control Circuit Diagram(SG-2130EB) (230V)

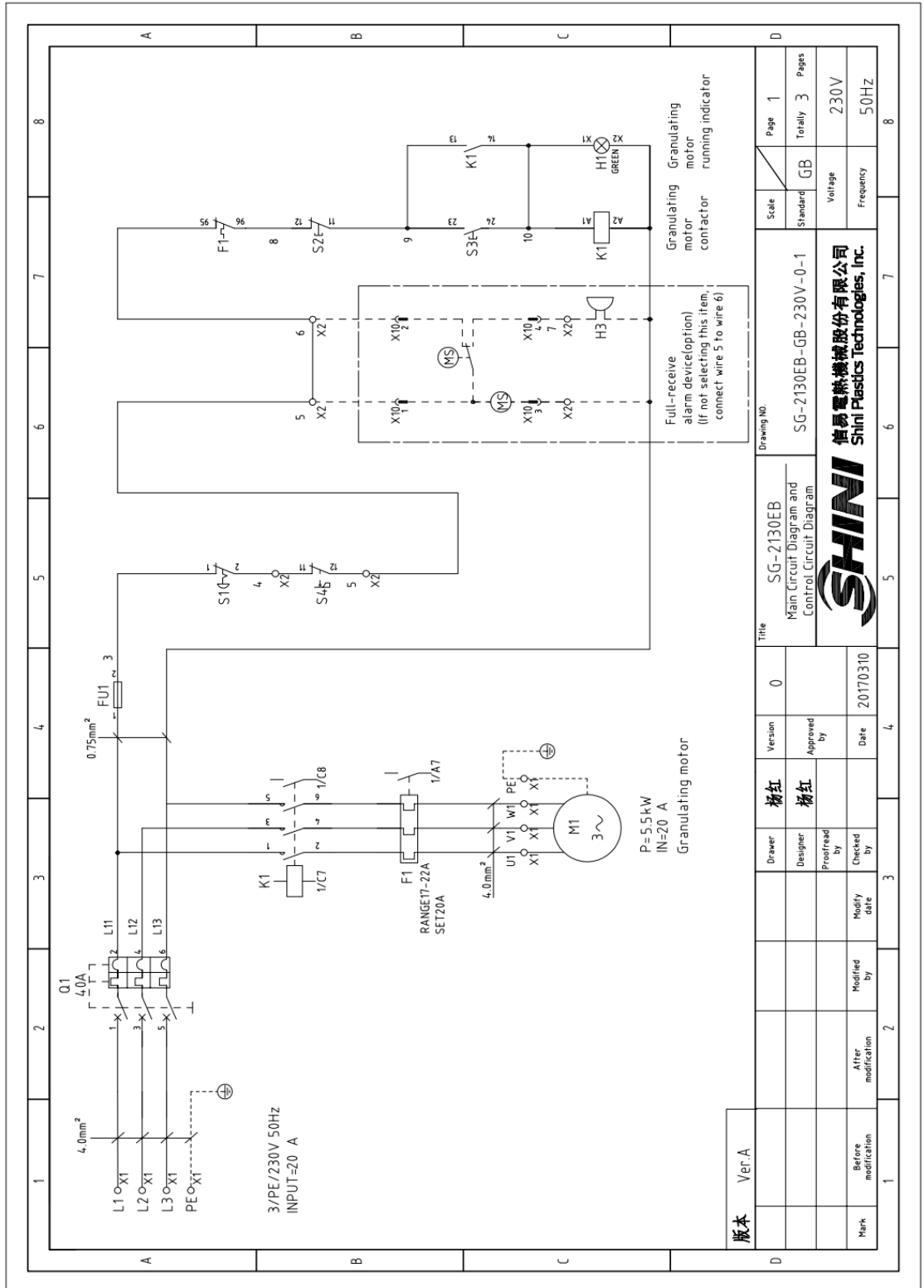

2.5.18 Electrical Components Layout(SG-2130EB) (230V)

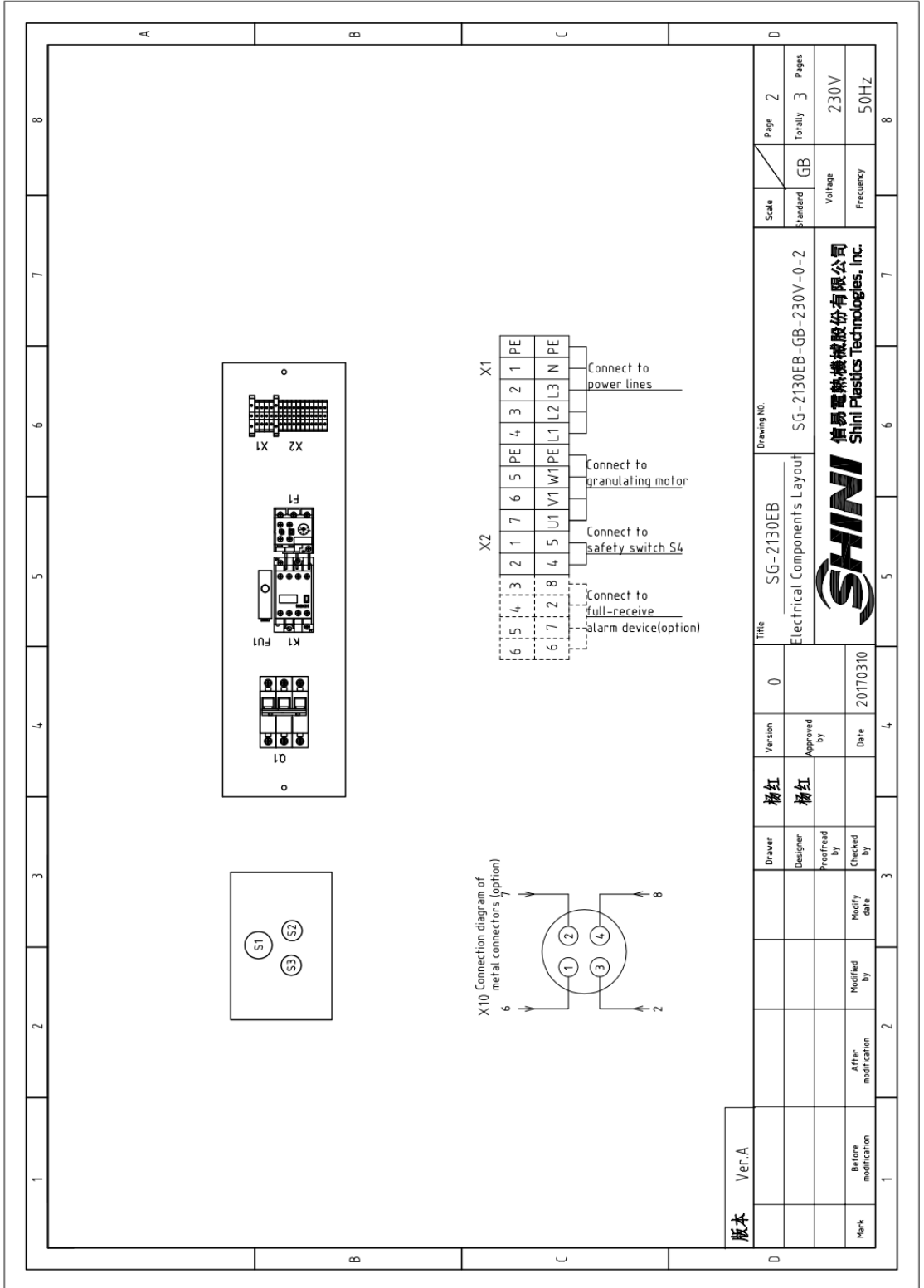

2.5.19 Main Circuit and Control Circuit Diagram(SG-2540EB) (230V)

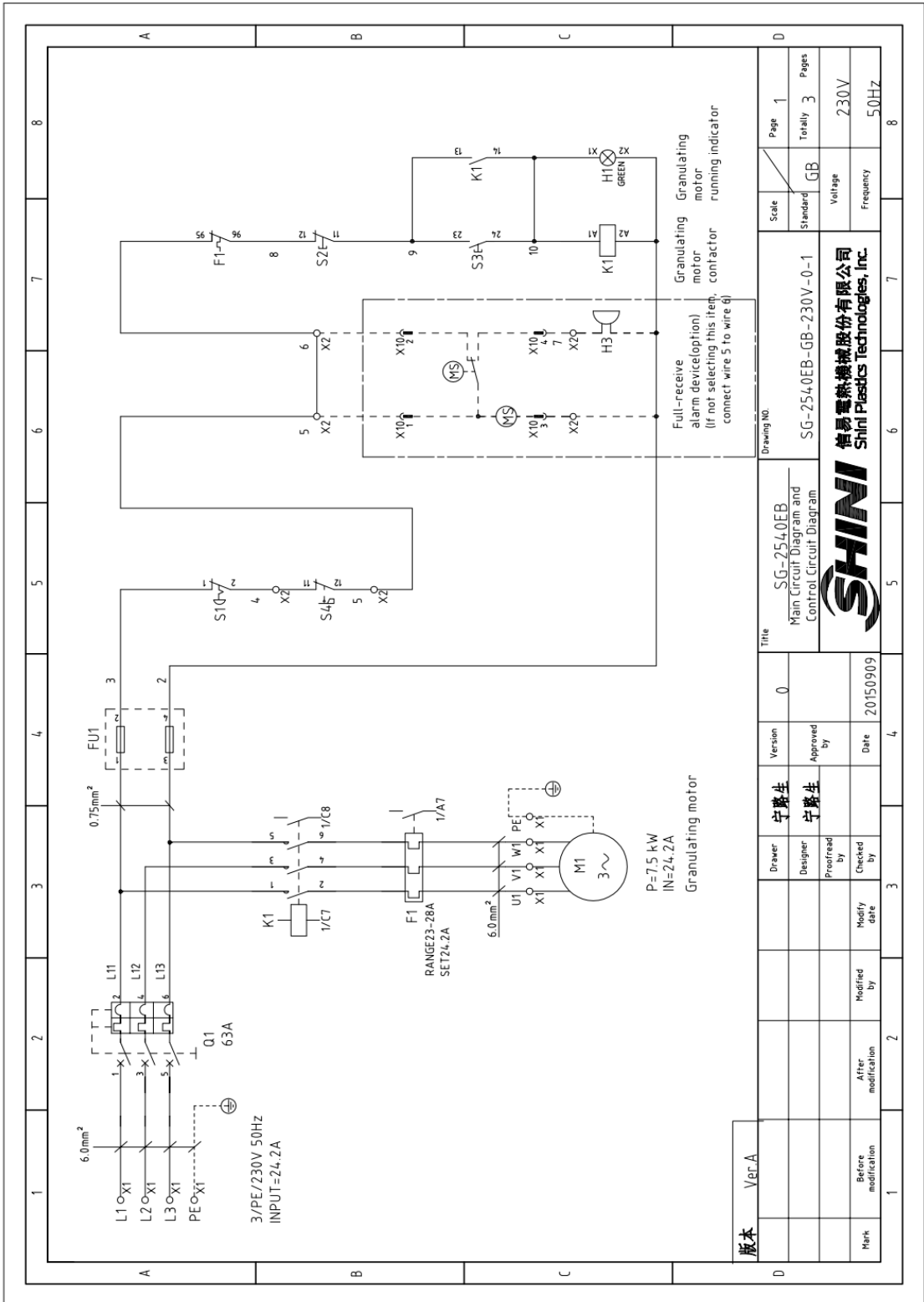

2.5.20 Electrical Components Layout(SG-2540EB) (230V)

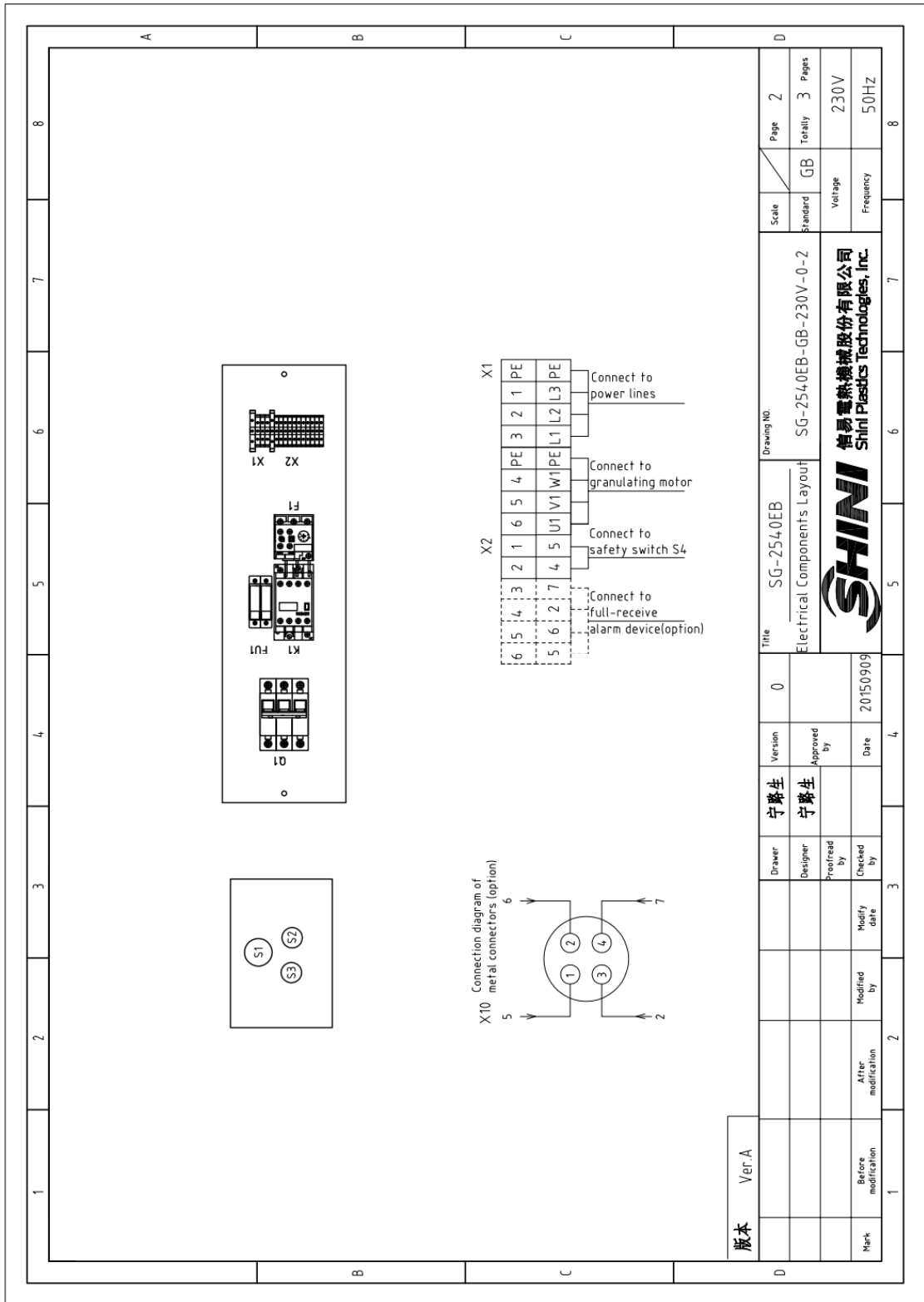

2.5.21 Main Circuit and Control Circuit Diagram(SG-2950EB) (230V)

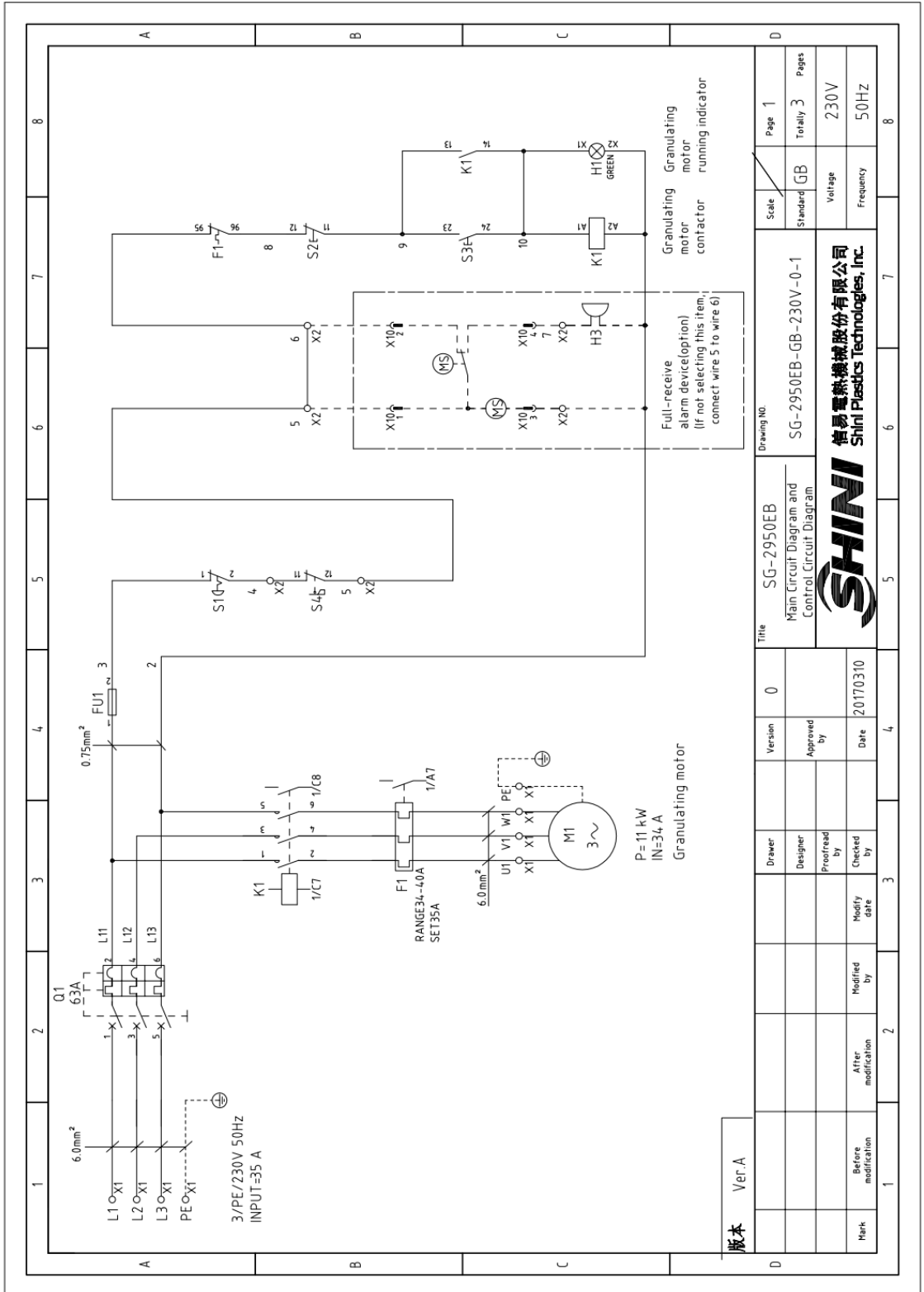

2.5.22 Electrical Components Layout(SG-2950EB) (230V)

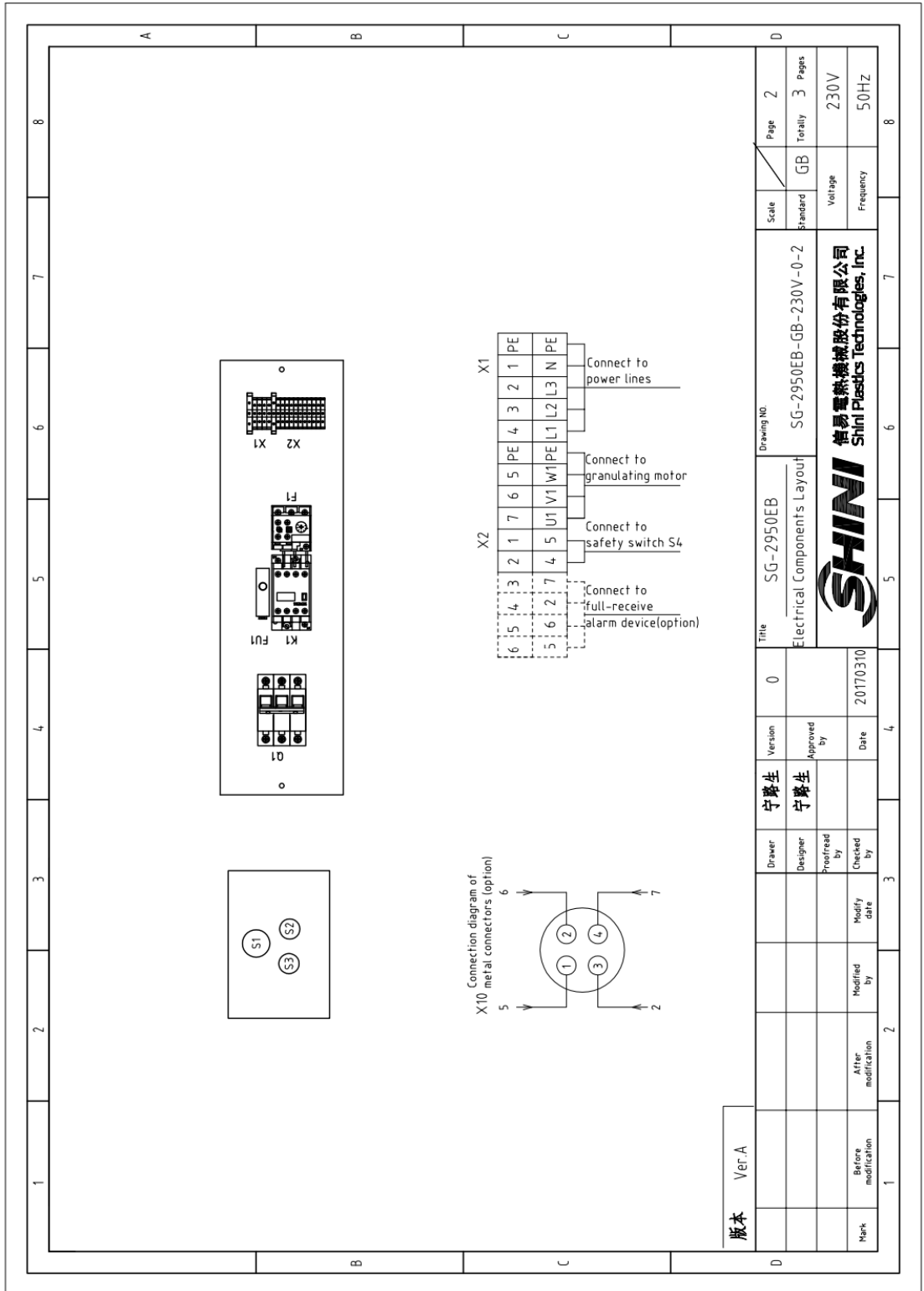

2.5.23 Electrical Components List(230V)

Table 2-15: Electrical Components List(SG-2130 EB) (230V)

NO.	Symbol	Name	Specification	Part NO.	Note
1	Q1	Circuit braker *	40A	YE40304003000	-
2	K1	Contacto**	220VAC 50/60Hz	YE00602722000	-
3	F1	Thermo overload relay	17~22A	YE01260170000	-
4	FU1	Fuse **	2A	YE41001000000	-
5	X1	Terminal board	4.0mm ²	YE60002503200	-
6			4.0mm ² PE	YE60002503500	-
7	X2	Terminal board	2.5mm ²	YE60002503200	-
8			2.5mm ²	YE60002503400	Option
9	H3	Buzzer	220VAC	YE84222000000	Option
10	S1	Emergency stop button	1NC	YE11411000000	-
11	S2	Stop button	1NC	YE11113100000	-
12	S3,H1	Start button	1NO	YE11100100000	-
13	S4	Safety switch	AZ-15	YE16147600100	-
14	MS	Materia level switch	220VAC	YE15000200100	Option
15	X10	Metal joint	4P	YE68025400000	Option
16			4P	YE68025400100	Option
17	M1	Granulating motor	230V 50Hz	-	-
18		Cable 4.0x5Cx4M	BA	BE51040500250	-

Table 2-16: Electrical Components List(SG-2540 EB) (230V)

NO.	Symbol	Name	Specification	Part NO.	Note
1	Q1	Circuit braker *	63A	YE40306303000	-
2	K1	Contacto **	220VAC 50/60Hz	YE00602822000	-
3	F1	Thermo overload relay	23~28A	YE01612620000	-
4	FU1	Fuse **	2P	YE41032200000	-
5		Fuse core**	2A	YE46002000100	-
6	X1	Terminal board	6.0mm ²	YE61060000000	-
7			6.0mm ² PE	YE61063500000	-
8	X2	Terminal board	2.5mm ²	YE61250040000	-
9			2.5mm ²	YE61250040000	Option
10	H3	Buzzer	220VAC	YE84222000000	Option
11	S1	Emergency stop button	1NC	YE11411000000	-
12	S2	Stop button	1NC	YE11113100000	-
13	S3,H1	Start button	1NO	YE11100100000	-

14	S4	Safety switch	AZ-15	YE16147600100	-
15	MS	Materia level switch	220VAC	YE15000200100	Option
16	X10	Metal joint	4P	YE68025400000	Option
17	-	-	4P	YE68025400100	Option
18	M1	Granulating motor	230V 50Hz	-	-
19		Cable 6.0x5Cx5M	BA	BE51060500250	-

* means possible broken parts. ** means easy broken part. and spare backup is suggested.

Please confirm the version of manual before placing the purchase order to guarantee that the item number of the spare part is in accordance with the real object.

Table 2-17: Electrical Components List (SG-2950 EB) (230V)

NO.	Symbol	Name	Specification	Part NO.	Note
1	Q1	Circuit braker *	63A	YE40306303000	-
2	K1	Contacto **	220VAC 50/60Hz	YE00602822000	-
3	F1	Thermo overload relay	30~36A	YE01612630000	-
4	FU1	Fuse **	2A	YE41001000000	-
5	X1	Terminal board	6.0mm ²	YE60000603200	-
6			6.0mm ² PE	YE60000603500	-
7	X2	Terminal board	2.5mm ²	YE60002503400	-
8			2.5mm ² PE	YE60002503400	Option
9	H3	Buzzer	220VAC	YE84222000000	Option
10	S1	Emergency stop button	1NC	YE11411000000	-
11	S2	Stop button	1NC	YE11113100000	-
12	S3,H1	Start button	1NO	YE11100100000	-
13	S4	Safety switch	AZ-15	YE16147600100	-
14	MS	Materia level switch	220VAC	YE15000200100	Option
15	X10	Metal joint	4P	YE68025400000	Option
16			4P	YE68025400100	Option
17	M1	Granulating motor	230V 50Hz	-	-
18		Cable 6.0x5Cx5M	BA	BE51060500250	-

*means possible broken parts. ** means easy broken part. and spare backup is suggested.

Please confirm the version of manual before placing the purchase order to guarantee that the item number of the spare part is in accordance with the real object.